

BLUEMASSMED SYSTEM VIEW
PRIMARY NODE, SECONDARY NODE AND NETWORK REQUIREMENTS



Reference : 2011 -

Version : 1.0

Contract number 2011 xx yyyy

Object : **Technical specification for BMM
Nodes participating the BMM demo**

Validation:	BMM STEERING GROUP	Date	Visa
		16.05.11	

RÉDACTION

	Name	Entity
Author	RAdm Osvaldo BROGI	Technical WG (Leader)
Contributors	Stefano SORGE	Technical WG
	Fabrice LESAINE	Technical WG
	All Primary Nodes Technical Managers	Technical WG

TRACK CHANGES

Version	Date	Page(s) & § concerned	Change description
0.1	04.04.2011	Whole document	Initial draft
0.2	30.04.2011	Pag.13 - §2 Primary & Secondary Nodes interface description (SV-1)	BMM XMSN data and information exchange will be only based on request-reply message pattern.
		Pag.20 – [Req.3.6] Restrictions and Limitations	With reference to BMM XMSN demonstration environment, the limitation in access on specific track data fields will be an optional item.
		Pag.23 - §4.1.5 Portal Management	Added Req.4.25 bis and Req.4.25 ter to consider the capability to insert data by a BMM Secondary Node via web portal exposed by a BMM Primary Node.
		Pag.26 - §5 Data Exchange Requirements (SV-6)	BMM XMSN data and information exchange will be only based on request-reply message pattern.
0.2	30.04.2011	Pag.29 - §6 BMM Data Model	Title “BMM Data Model” changed in “BMM Data Structures”.
		Pag.29 - §6.1 BMM XMSN Reduced Data Model	Title “BMM XMSN Reduced Data Model” changed in “BMM XMSN Reduced Data Structures”.
			[Req.6.1] – Inserted new data records.
1.0	16.05.2011	§0.4 – Terminology	Complements
		§1.1 – BMM Operational Nodes	Precision : Primary Nodes (only) host application layer implementing BMM services (<i>Observation from Greece</i>)
		§1.1.1 - BMM XMSN Demonstrator Nodes	Req 1.1 : give the list of the Primary Nodes Req 1.2 : report to Annex 1
		§1.2.1 – BMM XMSN Demonstrator Network	Req 1.4 : https/ssl protocol over the Public Internet Req 1.6 : https/ssl + certificates

		<p>§1.3.1 - BMM Services implemented in the XMSN Demonstrator</p> <p>§2.1 - XMSN Demonstrator Standard Components and Interfaces</p> <p>§ 2.2 - XMSN Demonstrator Primary Node Nation-specific Components</p> <p>Chapter 5 - Data Exchange Requirements (SV-6)</p> <p>§ 6.1 (Req 6.1)</p> <p>§ 8 - BMM XMSN Demonstrator compliance matrix</p> <p>Annex 1</p>	<p>Req 1.7 : modification taking into account that BMM XMSN is only Public Internet</p> <p>Req 1.8 : Add one common service (S4)</p> <p>Req 2.1 : xxxxxxxxxxxx</p> <p>Req 2.3 : Precision about the link between Primary Nodes and “dependent” Secondary Nodes</p> <p>Req 2.4 : Complements in the list of systems and assets, including the table of type of data</p> <p>Req 2.5 : Complements in the list of limitations</p> <p>Previous Req 5.4 is placed in the beginning in Req 5.1 and new Req numbering. Add precisions (including UML schemes, added methods) to Req 5.2 to 5.4. Add a new Req 5.5 dedicated to “Data Augmentation Service” (common service S4)</p> <p>Modification of data types for data #38 – 40 – 43 – 44</p> <p>Precisions and report to Annex 1</p> <p>Insertion of Annex 1 as shown during Athens Steering Group meeting (April 14th)</p>
2.0	12/07/2012	Whole document	Final Revision in accordance to VIP Demo implementation

TABLE OF CONTENTS

0	GENERALITIES	6
0.1	Purpose of the present document	6
0.2	Applicable documents.....	6
0.3	Reference documents.....	7
0.4	Terminology	7
1	INTRODUCTION	8
1.1	BMM Operational Nodes	8
1.1.1	BMM XMSN Demonstrator Nodes	9
1.2	BMM Network	9
1.2.1	BMM XMSN Demonstrator Network	10
1.3	BMM Services	10
1.3.1	BMM Services implemented in the XMSN Demonstrator.....	11
1.4	Overview of the Document.....	12
2	PRIMARY & SECONDARY NODES INTERFACE DESCRIPTION (SV-1)	13
2.1	XMSN Demonstrator Standard Components and Interfaces.....	14
2.2	XMSN Demonstrator Primary Node Nation-specific Components	18
3	COMMUNICATION & INFORMATION EXCHANGE DESCRIPTION (SV-2 / SV-3).....	20
3.1	XMSN Demonstrator Communication Requirements (SV-2)	20
3.2	Node to Node Information Exchange description (SV-3).....	20
3.3	XMSN Node to Node Requirements.....	21
4	BMM FUNCTIONALITY DESCRIPTION (SV-4)	23
4.1	Functionalities related to the implementation of the BMM Core Services	23
4.1.1	User Management (USM) Function	23
4.1.2	User Authentication (USA) Function	23
4.1.3	Service Management (SEM) Function	24
4.1.4	Service Authorization (SEA) Function	24
4.1.5	Portal Management	24
4.1.6	Map Management	25
4.2	Functionalities related to the implementation of the BMM Common Services	25
4.2.1	TS Function – Time Stamping & Geo Reference.....	25
4.2.2	TM Function – Track Management.....	26
4.2.3	TEX Function - Track Exchange	26
4.2.4	TSAC Function - Track Synchronisation, Association & Correlation	26
4.2.5	RMM – Rapid Mapping Management.....	27
4.3	BMM Function to BMM SERVICE Matrix (SV-5)	27
4.4	XMSN Service Provision (SV-12).....	28
5	DATA EXCHANGE REQUIREMENTS (SV-6)	29
5.1	XMSN Primary Nodes Web Services Definitions	29
5.1.1	[Req. 5.2] Track Data & Information Exchange Service – Web Services Definitions	29
5.1.1.1	Service Overview	29
5.1.1.2	Service Operational Concepts	30
5.1.1.3	Consumer Interface Methods Description.....	32
5.1.2	[Req.5.3] Regional Track Correlation Service – Web Service Definitions	34
5.1.2.1	Service Overview	34
5.1.2.2	Service operational concepts	34
5.1.2.3	Consumer Interface Methods Description.....	34
5.1.3	[Req.5.4] Wide Area Rapid Mapping Service – Web Service Definitions	35
5.1.3.1	Service Overview	35
5.1.3.2	Service operational concepts	35

	5.1.3.3 Consumer Interface Methods Description.....	35
5.1.4	[Req.5.5] Data Augmentation Service – Web Service Definitions	36
	5.1.4.1 Service Overview	36
	5.1.4.2 Service operational concepts	36
	5.1.4.3 Consumer Interface Methods Description.....	37
	5.1.4.4 Producer Interface Methods Description.....	37
6	BMM DATA STRUCTURES (SV-11).....	39
6.1	BMM XMSN Reduced Data Structures	39
	<i>Data Model Traceability Matrix System View vs wsd</i>	41
7	BMM QUALITY REQUIREMENTS DESCRIPTION (SV-7).....	42

ANNEX I - Procedure for the Establishment of the Shared Basic Common Maritime Picture (SBCMP)

ANNEX II – Track Correlation Alternative Solution

ANNEX III – WSDL rev.1.2.1

0 GENERALITIES

0.1 Purpose of the present document

The BMM System View is a set of graphical and textual products that describes systems and interconnections providing for or supporting the implementation of the BMM network environment.

The System View specifies the necessary systems resources and capabilities for the implementation of the Operational View and the Service-Oriented View defined by the BMM CCTP. These systems are the resources that are used to build the services of the Service-Oriented View, and support the operational activities, facilitating the exchange of information among operational nodes as defined in the Operational View.

According to the specifications developed so far, the future EMSN architecture, resulting from the BMM project activities, shall include three main components:

- The Primary Nodes, i.e. the SOA-adapted National Systems participating in the BMM information sharing environment through the harmonised exchange of added value services and data, thus feeding the (virtual) Shared Basic Common Maritime Picture¹
- The Secondary Nodes, i.e. the adapted National Systems participating in the BMM information sharing environment through a web-browser connection to the Primary Nodes web portals or National and European agencies willing to access the (virtual) Shared Basic Common Maritime Picture;
- The BMM Network, i.e. the communication architecture needed to establish a transport mechanism among the Primary and Secondary Nodes, supporting the platform independent exchange of core and common services across the nodes, basic information protection measures, and QoS requirements negotiation and enforcement.

Other National Systems implementing SOA capabilities (Operational Nodes) can be directly interfaced to National Primary Nodes through local Service Bus in order to improve exchange of data and services.

The present document (BMM System View) reports the description of the main system components and functionalities applicable to the Primary and Secondary Nodes and to the Network, according to the NAF methodology followed so far in BMM.

Moreover, preliminary specifications are derived for the XMSN demonstration platform, which will demonstrate under pre-defined and realistic operational scenarios the BMM service oriented capabilities.

Such specifications shall be turned to the full scale EMSN specifications based on the outcomes of the demonstrations, and will be a major contribution to the Final Report of the BMM project.

0.2 Applicable documents

[A-1] CAHIER DES CLAUSES TECHNIQUES PARTICULIERES (CCTP)

¹ within BMM, the SBCMP is not a single real picture residing in one single centralised dB but it is the picture resulting from all the tracks that the Primary Nodes have decided to exchange and it is distributed over all the Primary Nodes tracks dBs. We have synthesized this concept calling it a "virtual" picture.

0.3 Reference documents

[R-1] NATO Architecture Framework (NAF) version 3.0

0.4 Terminology

Sigle	Signification	Remark
BMM	Blue MaSS Med	Blue Maritime Surveillance System for the Mediterranean sea. Pilot Project launched by the European Commission (Directorate-General for Maritime Affairs and Fisheries - DG MARE), dedicated to the study of a future European capacity of a permanent surveillance of the Mediterranean maritime area and its Atlantic approaches
CCTP	Cahier des Clauses Techniques Particulières	
DG MARE	Directorate-General for Maritime Affairs and Fisheries	
EC	European Commission	
EU	European Union	
SBCMP	Shared Basic Common Maritime Picture	
XMSN	eXperimental Maritime Surveillance Network	

1 INTRODUCTION

The Blue Mass Med (BMM) Project is a Pilot Project for the definition of the architecture of the future European wide Maritime Surveillance Network.

BMM goal is to propose a model through which the existing maritime surveillance systems (MSS) of BMM partners and the other available commercial products (such as AIS, VMS, LRIT) contribute to build a **shared basic common maritime picture (SBCMP)** and to expose BMM services, which will enhance the regional maritime situational awareness.

BMM project aims, as well, to develop methodologies and standard operating procedures (SOP) shared by all the European Union Member States for the exploitation of the European Maritime Surveillance Network (EMSN), taking into account the dual use of EMSN (civil and military).

To help the definition of the EMSN, learning from experiment, the BMM Pilot Project Demonstration Phase will establish an eXperimental Maritime Surveillance Network (XMSN) to connect existing monitoring and integrated tracking systems together through a federated architecture.

This report, the BMM System View, defines the basic principles of the BMM full scale network (EMSN) and the detailed technical requirements that will be implemented on the BMM operational nodes that will be part of the eXperimental Maritime Surveillance Network (XMSN) of the BMM Demonstrator.

1.1 BMM Operational Nodes

The **Operational Nodes** in Blue Mass Med are the agencies that are partners. A BMM node is defined as an agency or partner which:

- produces information related to maritime surveillance and is able to make it available to other nodes by publishing it, so that the nodes that are interested in that information can subscribe.
- consumes information related to maritime surveillance published by other nodes.

Two types of BMM nodes are defined:

- **Primary Nodes:** a Member State node that implement the BMM common interface and can publish BMM services.
- **Secondary Nodes:** the adapted National Systems participating in the BMM information sharing environment through a web-browser connection to the Primary Nodes web portals or National and European agencies willing to access the (virtual) Shared Basic Common Maritime Picture through a web-browser connection.

BMM will be Service Oriented, meaning that no pure data access or data repository is foreseen in the network. No global, remotely accessed situation database is created in the global EMSN architecture. The database will be a local data repository that will collect and store data and information, acquired by its own national legacy system or exchanged via BMM services.

BMM **Primary** nodes are **virtual nodes** that host a Common BMM Application Layer implementing BMM services available for other BMM nodes having the necessary privileges.

Note: “virtual nodes” means that BMM nodes are not newly developed nodes, but they will result from the adaptation of existing National systems to the BMM network through a suitable application layer, containing

	This document belongs to BlueMASSMED project's Partners. Any copy or use is forbidden without a prior written authorisation.	
--	--	--

standard components and nation-specific components, and overall responding to BMM system specifications.

Nodes will be left the maximum freedom to implement and grant added value services to the BMM community. BMM services can be implemented adapting native services of the existing legacy systems or adding additional service chains to comply with recognised Maritime Community service requirements.

At national level, BMM nodes will be interfaced, by Local Service Bus, gateways, adapters or dedicated peer-to-peer connections, to available National systems in order to exchange maritime data and information.

In an architectural perspective, the Primary Nodes will be seen as National Systems adapted so as to:

1. feed the SBCMP implementing the BMM common and core services in accordance to the data model and the Service-Oriented-Views reported in BMM CCTP ;
2. provide access to the SBCMP for the Secondary Nodes through dedicated web-portals.

1.1.1 BMM XMSN Demonstrator Nodes

[Req.1.1] The BMM XMSN Demonstrator shall consist of the following Primary Nodes (see Annex 1 for the census of all the BMM Nodes):

1. *Italian Primary Node : Interagency*
2. *French Primary Node : Interagency (Navy, Customs, Maritime Affairs)*
3. *Spanish Primary Node 1 : Armada*
4. *Spanish Primary Node 2 : Guardia Civil*
5. *Portuguese Primary Node (double instance) : Marinha & Guarda Nacional Republicana*
6. *Maltese Primary Node : Armed Forces*

[Req.1.2] The BMM XMSN shall comprise the following Secondary Nodes. A secondary node shall be connected either to its national Primary Node through a Local Area Network or directly to other (foreign) Primary Nodes through the BMM Network, as indicated in Annex 1.

[Req.1.3] Primary nodes shall be able to assure services to Secondary Nodes, granting access to available web portal adapted to BMM requirements, and providing access to BMM SBCMP and related services to authorized BMM Secondary Nodes.

1.2 BMM Network

The BMM Network will be designed to support flexible sharing, integration and exploitation of heterogeneous Maritime Surveillance Data by Competent Authorities.

As dictated by the CCTP, the **BMM Networking Architecture** will be an open, flexible network based on a net-centric and non centralized approach: no central controlling entity, but a distributed virtual BMM centre over each node.

The basic implementation choice for this kind of network is generally recognised to be the creation of a WAN connection over the TCP/IP public network, with the proper VPN and information protection mechanisms to ensure a secure, transparent and guaranteed end-to-end transport layer among the network nodes.

Access protocols like ADSL/SDSL or B-ISDN shall be specified for the particular nodes not having a direct wide-band connection to the Public Internet at National System level.

Particular care shall be taken in reference to the implementation of the dual-use architecture specified in the CCTP for the handling of basic and classified data packages over the same public network through the exploitation of IEG mechanism and network diode for physical layers decoupling. These aspects shall be addressed in detail in the final version of this document, whereas they will be considered not applicable to the specifications of the XMSN demonstrator implementation, which will be limited to a single transport layer conveying all kind of data packages under the basic information protection measures provided by IPsec and secure VPN protocols. Only unclassified data (basic and non-basic as well as sensitive and non sensitive) will be exchanged using the XMSN.

1.2.1 BMM XMSN Demonstrator Network

[Req.1.4] The BMM XMSN Network shall be a broadband TCP/IP network implemented through [https/ssl](#) protocol over the Public Internet.

[Req.1.5] The BMM XMSN Network shall take into account the source data rates expressed in the census of the Primary Nodes and Secondary Nodes (Annex 1).

[Req.1.6] The BMM XMSN Network shall provide basic information security measures based on [https/ssl](#). One BMM Partner shall be designed to ensure the delivery of the required certificates.

[Req.1.7] Each Primary Node has to assign one skilled technical administrator to ensure Network Administration (@IP, certificates, ...). ~~for the purpose of the demonstration execution shall be assigned to one specific node at run-time, and shall have proxies in all other primary nodes, in order to allow maximum flexibility of the network configuration and scenarios execution~~

1.3 BMM Services

The BMM Network is based on a Service-Oriented-Architecture, assuring cooperative nodes to share information accessing services providing added value information for the enhancement of the Maritime Situational Awareness.

According to the CCTP, the following service taxonomy has been defined: BMM Common Operating Picture, BMM Satellite, BMM Information Assurance, BMM Service Management and Control, and BMM Community services.

BMM Common Services are the Operational Services enhancing the awareness and decision support capability of each connecting node and complying with (i) the basic User requirements to provide a SBCMP and (ii) the other (added value) User requirements to provide added value functions.

The purpose of the common services is to provide a SBCMP and added value services for its exploitation, in order to understand the operational domain in terms of services supporting operational activities.

BMM Core Services are the System Services providing the core functions for the proper operation of the BMM network as well as the auxiliary functions for the connectivity, management, etc., and complying with (i) the basic User requirements to provide a SBCMP and (ii) the additional User requirements to provide auxiliary connectivity functions.

The purpose of the core services is to provide essential services for assuring the correct operation of the BMM network and good connectivity and flexibility of cooperation among the connected nodes.

	This document belongs to BlueMASSMED project's Partners. Any copy or use is forbidden without a prior written authorisation.	
--	--	--

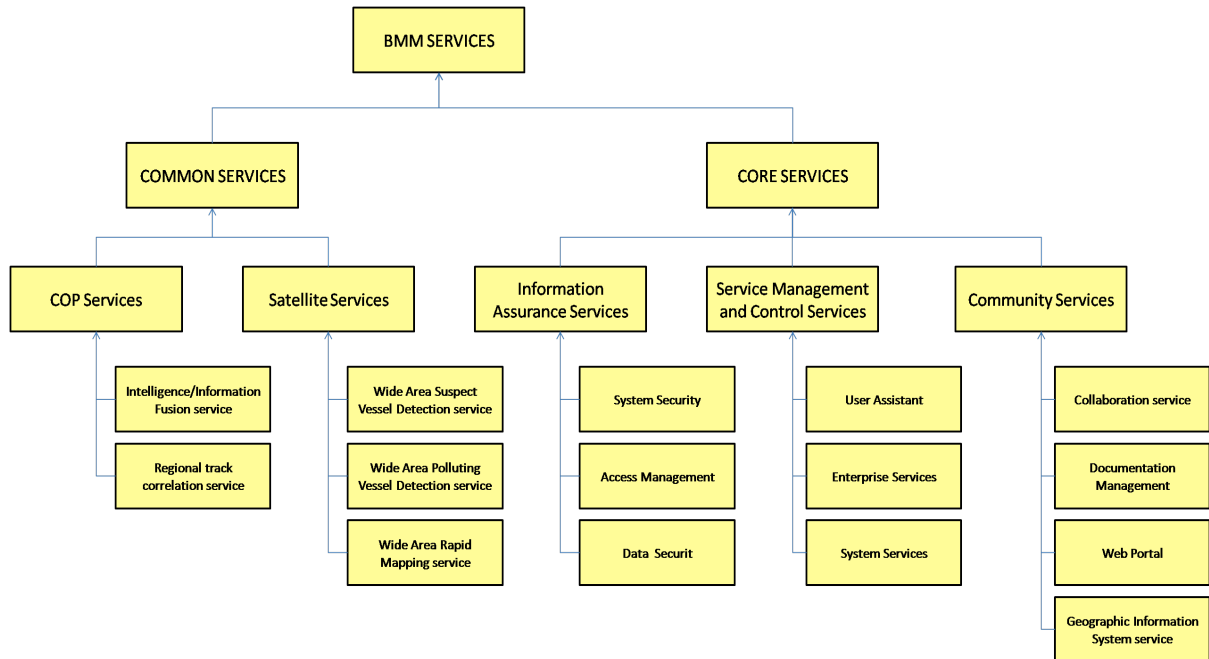

A limited set of these services has been proposed for implementation in the frame of the XMSN demonstrator in order to validate operationally the basic feature of the future EMSN concept.

1.3.1 BMM Services implemented in the XMSN Demonstrator

[Req.1.8] Within the scope of BMM XMSN demonstration, BMM primary nodes should provide the following reduced set of **services**, responding to the broad definition of the BMM Service Categories defined in the BMM CCTP:

- **Common Services**

- S1. Track data / information exchange (COP service, implementation of CS2 defined in the CCTP);
- S2. Regional correlation (COP service, implementation of CS2 defined in the CCTP);
- S3. Wide Area Rapid Mapping (Satellite service, implementation of CS5 defined in the CCTP);
- S4. **Data Augmentation Service (Limited implementation of CS1 defined in the CCTP).**

- **Core Services**

- S4. Web Portal and WebGIS (Community services);
- S5. Identity & Access Management (Information Assurance Services);
- S6. Service Registry Management (Service Management & Control services);

[Req.1.9] The Web Portal will provide BMM users with a secure and user-friendly Web Based front-end application, which enables them to dynamically and interactively access to a wide range information and application services provided within BMM Network.

[Req.1.10] The WebGIS Service will provide support for accessing and exploiting raster, vector and satellite maps within BMM Network, according to the (WMS 1.1.1 or better) and WFS standards.

[Req.1.11] The Identity & Access Management will assure the respect of BMM Authentication and Authorization policy, maintaining a federated database of identity, where username, password and role are assigned to each user.

	This document belongs to BlueMASSMED project's Partners. Any copy or use is forbidden without a prior written authorisation.	

[Req.1.11b] The Service Registry Management will ensure a standard and common definition of BMM web services and will verify that BMM users are able to invoke services and to access data according to a pre-defined BMM Data Distribution Policy.

[Req.1.12] The Track Data & Information Exchange Service will assure the capability to provide BMM Users (both local and remote) with current-time and/or historical track information available from connected National Systems and associated to targets already identified by the requesting entities (by IMO number, Ship Name, MMSI) in an area of interest.

[Req.1.13] The Regional Track Correlation Service will assure the capability to provide BMM Users (both local and remote) with current-time and/or historical track information correlating to track information held by requesting entities on the base of the available data from connected National Systems and of pre-defined levels of confidence and integrity.

[Re.1.14] The Wide Area Rapid Mapping service will provide BMM Node Users with the capability to exchange Satellite Geospatial Products (including SAR images) available from their respective National Systems, over an Area of Interest or a Track of Interest.

The actual transfer of Raster, Vector and Satellite Maps shall occur through file transfer according to WMF and WGF standards

1.4 Overview of the Document

This report, the BMM System View, defines the system specifications of the BMM full scale network (EMSN).

According to the implementation plan of BMM Project, the EMSN specifications will be set in accordance to the results of the initial study phase (refer to CCTP technical specifications) and the results of the XMSN demonstration. Therefore, this report will be a working document that will be updated during the whole project life.

The overall EMSN specification is given according to the following NAF-based breakdown:

- §2: Primary & Secondary Nodes Interface Description (NAF SV-1)
- §3: Communication Description (NAF SV-2)
- §4: Node-to-Node Information Exchange Description (NAF SV-3)
- §5: Nodes functionalities description and functions-to-services allocation (NAF SV-4, SV-5 & SV-12)
- §6: Data Exchange Requirements (NAF SV-6)
- §7: Data Model (NAF SV-11)
- §8: Quality Requirements Description (NAF SV-8)

The SV are based on the Operational Views and the Service Oriented Views reported in the CCTP.

In the first issue of the SVs, the minimum system requirements to be implemented in the eXperimental Maritime Surveillance Network (XMSN) shall be included. The final version of the SVs shall take advantage from the results of the demonstration in order to validate the SVs with respect to the established OV and SOVs in the CCTP and draw the overall system requirements for the future full-scale system.

2 PRIMARY & SECONDARY NODES INTERFACE DESCRIPTION (SV-1)

The reference SOA Model of the BMM Primary, Secondary Nodes and Network architecture is reported in the Figure below, denoting the main system components.

As clear from the figure, the BMM Primary nodes shall assure:

- a national “back-end” side : an appropriate nation-specific interfaces with the national systems (green coloured boxes);
- a BMM Network “front-end” side : the implementation of a SOA-based interface to be used among connected Nodes (blue colored boxes), based on web services technology, and a common data model over the BMM network.

~~on one side appropriate nation specific point to point interfaces with the national legacy systems (green coloured boxes), and on the other side the implementation of the SOA based interface among connected Nodes (blue coloured boxes), based on web services and a common data model over the BMM network.~~

The interface among different nodes is implemented over a TCP/IP WAN and shall be composed of two separate interfaces:

- a full SOA-based web-service system-to-system interface for information and data exchange ~~between~~ among all BMM Primary Nodes (*INT_01*);
- a light-client ~~access~~ user interface (web-browser ~~with local GIS~~) which will ensure the access to all the functionalities made available by a BMM Primary Node from a BMM Secondary Node ~~for data access from a BMM Secondary Node to the BMM Primary Nodes (INT_02).~~

In general, Data and information exchange over the BMM network could be based on standard web-services following a **request-reply pattern and/or on asynchronous publish-subscribe patterns**, where Service Providing Nodes would offer services enabling subscription to data according to run-time discovered services descriptions and to the predefined data-types in accordance to the BMM data model.

A suitably selected *Enterprise Service Bus* would assure the proper handling of services interfaces, the message/services brokering, the service scalability and the dynamic orchestration, in order to guarantee the maximum level of interoperability among connected nodes.

Figure 2-1 : BMM EMSN components

Thanks to the adoption of a full SOA architecture, the future EMSN shall be the first system-of-systems in Europe for cross-sector cross-border Maritime Domain Awareness, capable to allow operational nodes, services and national assets to be added to the BMM network, modified or removed from the network adaptively, without any impact on the existing BMM network and need to modify the existing service infrastructure. Thanks to the suggested SOA architecture, different communities (fisheries, law enforcement, border control...) will be able to use different sets of BMM services according to their missions.

2.1 XMSN Demonstrator Standard Components and Interfaces

[Req.2.1] *The BMM demonstrator (XMSN), shall be composed of the following main standards components:*

- *Identity Access Management, implementing standards like SAML / XACML procedures and a shared Directory according to the LDAP standard;*
- *Service Management with simple ~~orchestration~~ logic services publish and discovery logic based on a UDDI Standard ~~for the~~ Service Registry*
- *System Portal with Web Interface according to commonly adopted standards like JSR168, JBR268 and WSRP*
- *WebGIS embedded in the Portal at Web Interface Level and implementing WGS84 coordinate system, as well as the most commonly adopted standards for maritime data visualisation (eg. AIS visualisation standard)*
- *Map and images management, according to OGC standards*
- *Standard SOA architecture based on web-services ~~technology~~ operated according to a synchronous (request-reply pattern ~~for instance~~) and asynchronous (publish and subscribe pattern ~~for instance~~) through a SOAP over HTTP / HTTPS protocol stack*
- *Application Server environment ~~J2EE/JEE~~ or compatible hosting a reduced set of common services:*
 - *Track data & information exchange*

	This document belongs to BlueMASSMED project's Partners. Any copy or use is forbidden without a prior written authorisation.	

- Regional track correlation
- Wide area mapping
- Temporary DB for BMM tracks storage, based on COTS Relational Spatial Enabled Databases like PostGIS, MySQL, *Postgre SQL* or Oracle

[Req.2.2] With reference to the reference architecture of the XMSN, reported in Figure 2 and described in Req. 2.1, the INT_01 Interface (from Primary Node to Primary Node) shall be implemented through:

- interface between other Primary nodes and the Service Registry component (UDDI interface)
- ~~interface between the Primary nodes and the Application Server (WS interface)~~
- interface between the Primary nodes and the Map Server (at least for Satellite images exchange)

The INT_01 Interface shall be mandatorily implemented by all the Primary Nodes participating in the XMSN demonstrator

[Req.2.3] With reference to the reference architecture of the XMSN, reported in Figure 2.1 and described in Req. 2.1, the INT_02 Interface (from Secondary Node to Primary Node) shall be implemented through:

- Direct interface between external users and the Web Portal of the Primary Node (Browser Interface)

All BMM Primary Nodes shall implement the INT_02 interface for the sake of local users connections to the Node. However, *when they give a service access to dependant Secondary Nodes as listed in Annex 1*, the BMM Primary Nodes shall implement the INT_02:

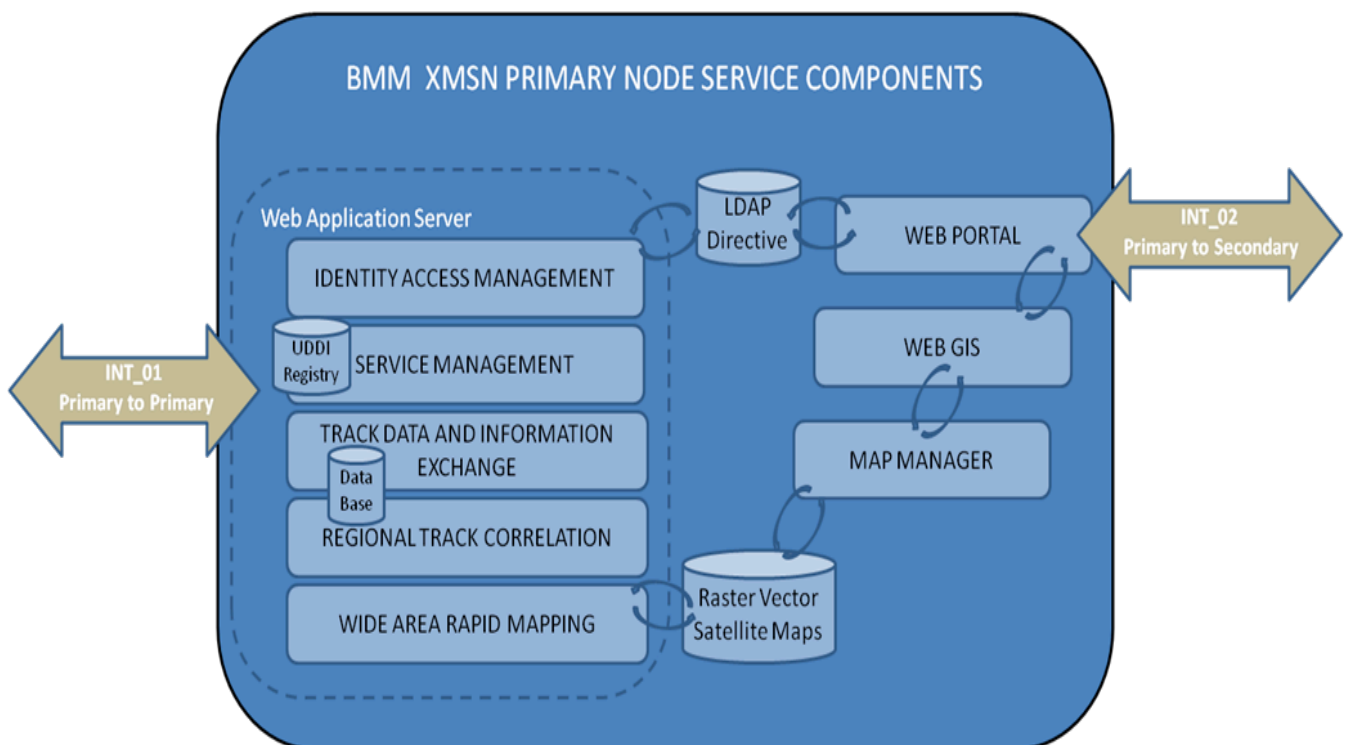

Figure 2-2 : BMM XMSN Primary Node Components

The following table shows the reference configuration proposed for the design of the Demonstrator Primary Nodes. Each PN shall adopt the indicated open source solutions or compatible commercial solutions in order to ensure the maximum interoperability of the demonstrator nodes.

Primary Node Services	Standards / Interface	Standard (Applications)	Open Source (Suggested Solution)
<i>Track data / information exchange</i>		Java SQL	JDK 1.6
	Web Services (SOAP, WSDL)	JAX-WS	Glassfish
		SQL	MySQL PostgreSQL
<i>Web Portal</i>	JSR 168 (1.0) JSR 286 (2.0) WSRP	Java	Liferay
<i>Web GIS</i>	WGS84 Mercator Projection AIS symbols Web Services (SOAP, WSDL)	PHP (Apache)	
<i>Map Server</i>	WMS 1.1.1 ADRG, ASRP, CADRG, USRP, CIB, SRG-IGM, GEOTIFF Rev.6.0, TIF + tfw/tab, JPG + jpw, Tiff + tab	PHP (Apache)	MapServer
	WFS 1.0.0 Shape File	PHP (Apache)	MapServer
<i>Identity & Access Management</i>	WS-Security (username/password) SSL (https) SAML / XACML		

Primary Node Services	Standards / Interface	Standard (Applications)	Open Source (Suggested Solution)
<i>Directory Service</i>	LDAP v3		Open LDAP
<i>Service Registry Management</i>	UDDI v3		jUDDI
<i>Regional correlation</i>		Java SQL	JDK 1.6
<i>Wide Area Rapid Mapping</i>	WMS 1.1.1 GIF, JPG, PNG ADRG, ASRP, CADRG, USRP, CIB, SRG-IGM, GEOTIFF Rev.6.0, TIF + tfw/tab, JPG + jpw, Tiff + tab		

2.2 XMSN Demonstrator Primary Node Nation-specific Components

[Req.2.4] The BMM nodes involved in the XMSN demonstrator as Primary Nodes, shall implement nation-specific interfaces (based on SOA interfaces or Point-to-Point interfaces) towards the following available national systems and assets:

- *Italian Primary Node :*
 - *National Coastal Surveillance System;*
 - *National VTMISS*
 - *National AIS network (MARES);*
 - *SIA - Ministry of Interior Information System*
 - *C4I – Guardia di Finanza Maritime Surveillance System*
 - *Dispositivo Integrato Interministeriale Sorveglianza Marittima (DIISM);*
 - *Coastal Surveillance Radars - Navy;*
 - *M&S COE system – Ministry of Defence;*
 - *COSMO Sky-Med Ground Station (Satellite SAR Images)*

- *French Primary Node:*
 - *National Maritime Surveillance and State Action at Sea Coordination System - SPATIONAV through OCEAN system interface ((correlated radar & AIS tracks).*
 - *Pleiades HR-Satellite (CNES)*

- *Spanish Primary Node 1 (Armada):*
 - *National MSA System (SIVICEMAR).*

- *Spanish Primary Node 2 (Guardia Civil):*
 - *SIVE (Maritime Border Surveillance and Protection System);*
 - *National AIS network.*

- *Portuguese Primary Node (two instances : Marinha & Guarda Nacional Republicana):*
 - *Coastal and Açores Surveillance System – COSMOS (Marinha);*
 - *Coastal Surveillance System – SIVICC (Guarda Nacional Republicana).*

- *Maltese Secondary Node (Armed Forces):*
 - *National VTS*

- *Greek Secondary Node (Coast Guard):*
 - *National VTS*

The following table shows, as a consequence of the above specifications, the overall coverage of the XMSN demonstrator in terms of geographic coverage and *data* types.

Zone	Coastal / VTS Radar	AIS & other SRS	LRIT, VMS	Satellite Radar	Satellite Optical
------	---------------------	-----------------	-----------	-----------------	-------------------

	This document belongs to BlueMASSMED project's Partners. Any copy or use is forbidden without a prior written authorisation.	

Atlantic Approaches	PT SP	PT SP1 SP2	SP1 SP2 IT	IT	FR
West Mediterranean	SP FR	SP1 SP2 FR IT	SP1 SP2 IT	IT SP1	FR
West-Central Mediterranean	SP FR	SP1 SP2 FR IT	SP1 SP2 IT	IT	FR
Central Med (Sicily Channel, Tirrenum & Adriatic Sea)	IT MT GR	IT MT GR SP1	IT SP1 GR SP2	IT	FR
East-Central Mediterranean (Aegean)	GR	IT GR SP1	IT GR SP1 SP2	IT	FR
East Mediterranean (Up to Suez and Cyprus)	GR	IT GR SP1	IT GR SP1 SP2	IT	FR

[Req.2.5] With reference to services to implement in the BMM XMSN demonstrator (see Req.2.1), the Primary Nodes shall be subject to the following exclusions and limitations:

- Italian Primary Node:
 - No exclusions and limitations
- French Primary Node :
 - No exclusions and limitations
- Spanish Primary Node 1 (Armada):
 - No exclusions and limitations
- Spanish Primary Node 2 (Guardia Civil):
 - One limitation : the vessel tracks of the SIVE system are classified and during the demonstration therefore the SIVE tracks will be fake tracks
- Portuguese Primary Node (Marinha & Guarda Nacional Republicana):
 - No Exclusions and limitations

3 COMMUNICATION & INFORMATION EXCHANGE DESCRIPTION (SV-2 / SV-3)

In general the BMM network shall consist of a WAN implemented through virtual private networks over the public internet infrastructure.

However, to provide handling and sharing of classified data a dual-use architecture will be adopted, and will assure that the BMM Node will consist of independent and separate areas to manage both classified and unclassified data.

The information protection issues can be address by leveraging ESB security features and protocol support such as WS-Security for authentication / authorization purposes at service level.

Moreover, the underlying communication channel (HTTP) can be also secured (HTTPS or other mechanism such as IP-SEC tunnels), which improves the overall security regarding inter-system communications.

The authentication and authorization process will determine which data the requesting node is authorized to access, and only that specific data set will be transferred.

3.1 XMSN Demonstrator Communication Requirements (SV-2)

The BMM communication description has to provide a comprehensive specification of how systems are connected at a detailed infrastructural level, what interfaces each system exposes (ports), the hardware interfaces used, and the protocols that govern transmission of data across the interfaces.

For the purpose of the realisation of the XMSN demonstrator a number of simplifications shall be made including:

- The implemented network among the Primary Nodes shall be a WAN over TCP/IP, supporting wide band access connections at all Primary Nodes and possibly at Secondary Nodes (through appropriate SDSL connection when a wideband internet connection is not immediately accessible)
- The Dual-Use architecture will not be implemented in the XMSN, since there will be no actual classified information within the demo, but the rationale of a dual use communication architecture shall be validated
- A secure transport layer based on secure VPN and on the use of HTTPS shall be adopted for the XMSN.

[Req.3.1] The following table defines the specifications of communication requirements for BMM nodes that will be involved in the BMM XMSN demonstration.

BMM Node	Type	IP Address	Supported Protocols
France	Primary	https://bluemassmed.eurocis.fr	https/ssl
Italy	Primary	https://itbmm.marina.difesa.it	https/ssl
Portugal 1	Primary	https://qa.compass.marinha.pt	https/ssl
Spain 1	Primary	https://bmm.covam.es	https/ssl
Spain 2	Primary	https://213.229.156.42	https/ssl

3.2 Node to Node Information Exchange description (SV-3)

BMM data exchange will be based on data already available at MSS level. The Information exchange is the data to be exchanged among the agencies mentioned previously, as reported in Appendix 2 of the CCTP.

The BMM EMSN shall be designed to support flexible sharing, integration and exploitation of such heterogeneous Maritime Surveillance Data by Competent Authorities. Nevertheless, non-public domain data

	This document belongs to BlueMASSMED project's Partners. Any copy or use is forbidden without a prior written authorisation.	

distribution among Users, will be ultimately dictated by the agreed service subscriptions between the different organizations at national (bilateral or multilateral) level.

To trade-off these two important aspects, BMM is based on the implementation of a flexible data distribution policy and plan, entailing the synchronisation of user directories and service registries at network level thanks to the application of the LDAP and UDDI standards, and the federation of the Identity & Access Management services among the BMM nodes, managing User credentials and authorisation profiles at BMM level but under the supervision of the respective National Stakeholders involved.

The Data Distribution Plan (DDP), resulting from the merger of the LDAP User Credential Directory and the UDDI Service Registry, will define, therefore, the limitations or restrictions applicable to a specific requesting entity and a specific service providing entity for any specific set of data packages and data types.

Combined with the need to integrate numerous countries & organizations, this means in practical terms that BMM shall provide identity federation for its user management. Identity federation implies the creation of circles of trust, i.e. applications (Service Providers) that mutually accept users identified through various identity providers. Conversely, each Primary Node shall remain free to apply its own security rules, organize user profiles in a convenient way and limit access to applications and data in the most suitable manner, assuming that such restrictions are in compliance with the shared Data Distribution Plan.

When a BMM node invokes a service onto the BMM network, the BMM primary nodes processing the request has to verify, firstly, if the requester can invoke the service and, secondly, the “level” of data it can access. Once processed the service request, the Primary Node can implement the service and publish on the BMM network the service response.

3.3 XMSN Node to Node Requirements

[Req.3.2] The XMSN demonstrator shall be capable to implement federated Identity & Access Management based on synchronised User Credential and BMM Primary Node available list of Service Registryes according to LDAP and UDDI standards.

Thus, in the XMSN environment, BMM Primary Nodes shall be able to handle a static and pre-defined Data Distribution Plan resulting from the above mentioned registries.

[Req. 3.3] Each BMM partner shall be identified on the XMSN network by a unique username, password and role. Username, password and roles will be set in a pre-defined and static table.

[Req.3.4] At each BMM Primary Node, when a BMM user requests access to the BMM network, a User Authentication procedure shall control that username and password are compliant with the value set in the pre-defined user credentials.

[Req.3.5] At each BMM Primary Node, when an authenticated BMM user asks to invoke a BMM service, a Service Authorization procedure shall look-up the DDP to find the restrictions and / or limitations to the access of the requesting User to services and data, as option, according to its credentials.

[Req. 3.6] The restrictions and limitations of access to the BMM services and data shall consist of:

- Denied access to one specific BMM service (S1, ..., S6);
- Denied access to the different groups of Data Packages (Basic / Sensitive²);
- Denied access to specific types or classes of tracks (by query on BASIC_ID_DATA)

² The same functionality could be extended to the management of unclassified / classified data access restrictions in the full-scale EMSN specification

	This document belongs to BlueMASSMED project's Partners. Any copy or use is forbidden without a prior written authorisation.	

- *[Optional] Limitations in access on specific track data fields (Basic_ID_Data, Basic_Voyage_Data, Historic_Data, Other_Data).*

[Req. 3.7] BMM XMSN User Credentials will be in accordance to the following definition:

- ***BMM Super Users, users of Primary Nodes***

They will be able to:

- *request / provide BMM common services through their legacy systems.*
- *manage BMM Network (core services) through the Primary Node*
- *administrate services and users (core services) through the Primary Node*

- ***BMM Full Access Users, will be able to:***

- *Provide data & information to the BMM network through specific adapters (SOA / P2P) to their legacy systems, implemented by the Primary Node*
- *Access BMM network through Primary Node web portal (with basic functions for data exchange like AoI, track data & track features entry, etc.)*

- ***BMM Users, will be able to access BMM network only through web portal of a Primary Node***

With reference to the BMM XMSN demonstrator, the following table provides the User Credentials of involved partners

	<p>This document belongs to BlueMASSMED project's Partners. Any copy or use is forbidden without a prior written authorisation.</p>	
--	---	--

4 BMM FUNCTIONALITY DESCRIPTION (SV-4)

The BMM Primary Nodes components requirements are described in the present section through the identification of basic functions and of their allocation to services.

4.1 Functionalities related to the implementation of the BMM Core Services

Concerning the Core Services functionalities, in the present version of the document we make explicit limitation to the functionalities included in the XMSN demonstrator.

The functionalities of the full scale EMSN components shall be specified in the final version of the document taking into account the lesson learnt from the demonstration.

The following functions shall be implemented in the BMM Primary Nodes:

- USM – User Management
- USA – User Authentication
- SEM – Service Management
- SEA – Service Authorisation
- POM – Portal Management
- MPM – Map Management

4.1.1 User Management (USM) Function

[Req.4.1] The User management shall assure the creation and maintenance of a BMM User Register.

[Req.4.2] The User management shall be able to add new users, delete existing users and modify users attributes.

[Req.4.3] At each BMM User shall be at least assigned a unique username and password and a BMM role.

[Req.4.4] BMM roles shall be set in accordance to a pre-defined ~~Data~~ Service Distribution Policy

[Req.4.5] BMM user role shall assign BMM services and level of data that the user may access.

[Req.4.6] User management shall be based on a federated approach, assuring that BMM nodes share the same BMM User Register data.

[Req.4.7] XMSN User Register shall comply with LDAP standard

[Req.4.8] BMM XMSN users credentials shall be set on a pre-defined and static table that will be implemented in the BMM XMSN nodes.

4.1.2 User Authentication (USA) Function

	This document belongs to BlueMASSMED project's Partners. Any copy or use is forbidden without a prior written authorisation.	
--	--	--

[Req.4.9] When a BMM user is logging to a BMM node, a user authentication function shall validate the username and password, and shall permit / refuse the access to the BMM network, in accordance to the user data included in the User Register.

[Req.4.10] Exchanging of authentication data shall be based on SAML/XACML standard.

4.1.3 Service Management (SEM) Function

[Req.4.11] The service management shall enable the discovery, publication, addressing and invocation of BMM services, ensuring their location and access to the relevant meta-data (tokens, wsdl and xsd) by the internal and external users.

[Req.4.12] The service management shall be able to add new services, delete existing services and modify service attributes.

[Req.4.13] The service management shall implement a server registry. The implementation shall be compliant with UDDI standard.

[Req.4.14] Being BMM based on a federated service management approach, BMM service registry shall consist of several UDDI nodes deployed on the different BMM primary nodes.

[Req.4.15] The service management shall support the implementation of ~~a simple orchestration~~ methods coordinating Service discovery and location, Identity & Access Management and actual service provision over the BMM network.

4.1.4 Service Authorization (SEA) Function

[Req.4.16] Service authorization shall be based on SAML / XACML request-response language.

[Req.4.17] The SEA function shall process requests from authenticated users applying the limitations and restrictions applicable to the User according to the established DDP and the user credentials / role.

4.1.5 Portal Management

[Req.4.18] Web Portal shall implement access control procedures on https.

[Req.4.19] Web Portal shall validate user credentials (username and password) of BMM users accessing the portal.

[Req.4.20] When a BMM user is authenticated, a web portal session shall be assigned to the user.

[Req.4.21] Exploiting the WebGIS capabilities, the Web Portal shall assure the visualization of raster, vector and satellite Maps.

[Req.4.22] BMM web portal users shall be able to select the layers that can be presented on maps.

	This document belongs to BlueMASSMED project's Partners. Any copy or use is forbidden without a prior written authorisation.	
--	--	--

[Req.4.23] BMM web portal users shall be able to select an object on maps and visualize a table representing main object attributes.

[Req.4.24] BMM web portal users shall be able to perform pan and zoom actions.

[Req.4.25] BMM Nodes shall access the web portal via web browser Explorer 7 (or newer) or Firefox 3.5 (or newer).

[Req.4.25 bis] BMM Secondary Nodes, accessing BMM Network via a web portal exposed by a BMM Primary Node, should be able to manually insert data on the BMM scenario (optional)

[Req.4.25 ter] BMM Primary Node shall be able to publish the data inserted by a BMM Secondary Node via web portal (optional)

4.1.6 Map Management

[Req.4.26] Web Portal, WebGIS and Map manager shall be able to support, import, manage and display standard maritime charts, *represented in common GIS file format as Geo Tiff 6.0, Geo Tiff + tfv, etc.*

[Req.4.27] Map requests shall be implemented according to the OGC Web Map Service 1.1.1 (or better) standard protocol.

[Req.4.28] Requests for geographical features shall be implemented according to the Web Feature Service Interface Standard (WFS).

[Req.4.29] BMM tracks shall be displayed on BMM maps that use WGS84 standard.

4.2 Functionalities related to the implementation of the BMM Common Services

The following functions shall be implemented in the BMM Primary Nodes participating in the XMSN:

- TSG - Time Stamping & Geo Reference (Ref. CCTP TECH_RQ 16)
- TRM - Track Management (Ref. CCTP TECH_RQ 10)
- TEX - Track Exchange (Ref. CCTP TECH_RQ 11)
- TRS - Track Synchronisation (Ref. CCTP TECH_RQ 12)
- TAC - Track Association & Correlation (Ref. CCTP TECH_RQ 12)
- RMM – Rapid Mapping Management (Ref. CCTP TECH_RQ 12)

The following sections specify the minimum requirements of the above listed functions, as far as the implementation of the demonstrator is concerned. Full requirements shall be derived in the final version of this document.

4.2.1 TS Function – Time Stamping & Geo Reference

[Req.4.30] BMM Nodes shall be able to time stamp all exchanged data among nodes, using Coordinated Universal Time (UTC).

	This document belongs to BlueMASSMED project's Partners. Any copy or use is forbidden without a prior written authorisation.	
--	--	--

[Req.4.31] BMM Nodes shall be able to geographically reference on a global scale all exchanged data among nodes, using the World Geodetic System 1984 (WGS-84).

4.2.2 TM Function – Track Management

The TM function shall take care of the management of tracks inside each node, dealing with Nation-specific interfaces to National Systems and providing basic operations on local BMM tracks.

[Req.4.32] The TM function shall exchange track data over point-to-point (or local SOA) interfaces with Nation-specific legacy systems, and shall adapt the exchanged data to the BMM data model.

[Req.4.33] – ~~[Optional]Not Applicable to the XMSN~~ - The TM function shall provide the Node operators with basic operations like the visualisation, assignment or modification of a track number, the analysis, modification or deletion of an existing track attributes.

4.2.3 TEX Function - Track Exchange

[Req.4.33a] The TEX function shall perform the basic operations supporting the exchange of track data among BMM nodes:

- Receive and handle the Local or Remote Users requests of services concerning track exchange
- Follow-up on-going services requests
- Process received BMM tracks from other nodes and extract the track data according to the BMM data model, storing the track data into the Node Track Temporary Data Base
- Execute the necessary functions according to the requesting services and involving the TS and TAC functions (see §5.5)
- Prepare BMM tracks for transmission to requesting nodes, according to the BMM data model, retrieving the track data from the Node Track Temporary Data Base

4.2.4 TSAC Function - Track Synchronisation, Association & Correlation

[Req.4.34] The TSAC function shall perform the basic operations supporting:

- synchronisation of tracks known different time of validity
- association of tracks (i.e. based on static or semi-static parameters matching)
- correlation of tracks, meaning the association of partially unknown tracks on the base of dynamic (kinematic) parameters matching.

[Req.4.34a] The TSAC Synchronisation function shall be capable to align the input track data to a common reference time instant, implementing standard prediction algorithms or, if necessary to recover large synchronisation gaps, back propagation and forward propagation algorithms.

[Req.4.34b] The TSAC Association function shall be capable to associate input and own tracks presenting a firm matching in static or semistatic parameters like MMSI, IMO Number, Ship Name and Call Sign, etc.

- The association function shall mark associated tracks as such, and merge them if requested.
- A suitable logic shall be applied to handle discrepancies in associated tracks data, based on the trustworthiness and accuracy of the respective origin.

[Req.4.34c] The TSAC Correlation function shall be able to correlate input tracks with own tracks matching in dynamic parameters like position / course / speed and their expected predictions / propagations, defining and assessing a confidence index of the correlation that will be used to indicate the usability of the correlation results.

The correlation can be based on a mix of deterministic, statistical methods as well as on adaptive tracking techniques, taking into account the specific characterisation of the different targets and a maximum time span among the tracks to be correlated up to several hours.

4.2.5 RMM – Rapid Mapping Management

[Req.4.35] The RMM function shall perform the basic operations supporting the exchange of satellite mapping products, (represented in common GIS file format as Geo Tiff 6.0, Geo Tiff + tfv, etc), among BMM nodes:

- Receive and handle the Local or Remote Users requests of services concerning rapid mapping
- Follow-up on-going services requests until the requested products are transmitted to the requesting entities

4.3 BMM Function to BMM SERVICE Matrix (SV-5)

BMM System View 5 is devoted to the allocation of BMM System Functionality defined in SV-4 on BM Services.

Following the BMM Pilot Project approach, SV-5 initial draft is referred only to the subset of functionalities and services that will be implemented on the BMM XMSN demonstrator.

Accordingly, SV-5 will be incremented along the project to reach the full scale BMM EMSN, taking into account the lesson learnt of BMM demonstrator.

Services Function	Track Data / Information Exchange	Regional Correlation	Wide Area Rapid Mapping	Web Portal and WebGIS	Identity and Access Management	Service Registry Management
USM - User Management				X	X	
USA - User Authentication	X	X	X		X	
SEM - Service Management	X	X	X			X
SEA - Service Authorization	X	X	X			X
POM - Portal Management	X	X	X	X	X	X
MPM - Map Management	X	X	X	X		
TSG - Time Stamping & Geo Reference	X	X	X			
TRM - Track Management	X	X				
TEX - Track Exchange	X	X		X		
TSAC - Track Synchronisation, Association & Correlation	X	X				
RMM – Rapid Mapping Management			X	X		
.....						

4.4 XMSN Service Provision (SV-12)

Outline BMM service in terms of system elements:

- *BMM Nodes,*
- *Architecture Building Blocks,*
- *System functions, Nodes / Blocks / functions collaboration.*

All PN shall insert here their own services operational concept (a sequence diagram for example).

5 DATA EXCHANGE REQUIREMENTS (SV-6)

In accordance to the adopted Service Oriented Architecture (SOA) approach, BMM Nodes interface will be based on the following paradigms:

- **Publish / Subscribe:** asynchronous communication where subscribers (receivers) express interest in one or more topics and where publishers have no knowledge of existing subscribers. The communication is based on notification mechanisms, allowing the decoupling of both roles;
- **Request / Response:** typically used for synchronous and immediate communication between services.

Considering the overall scope of BMM XMSN and the limited number of services to be implemented, the BMM XMSN data and information exchange will be only based on request-reply message exchange pattern. This would allow the maximum interoperability and platform independence of the connected nodes, avoiding the need of using poorly standardised middleware like JMS and DDS or not yet mature standards like the WS Notification.

Consequently, the data exchange shall be implemented in the XMSN through platform independent Web Services (WS) encapsulating data complying to the established BMM Data Model.

The standard interface will be implemented therefore specifying at each Node:

- The Web Service semantic and modalities for execution through the WSDL, for the basic services and service methods applicable to the Nodes;
- The involved input and output data description through eXtensible Markup Language (XML) format, establishing the tags for semantic common understanding (XML Schema Definition - XSD).

Accordingly, the Primary Node shall implement a protocol stack (complying with J2EE standard) featuring:

- WS (WSDL, XSD, ...) and potentially evolutions to WS-S
- Simple Object Access Protocol (SOAP)
- Hypertext Transfer Protocol over Secure Socket Layer (HTTP / HTTPS)
- TCP/IP

Conversely, at national level, legacy systems shall be connected to the BMM network by specific adaptors which will be part of the national BMM virtual node. Each adaptor will implement the MSS specific data processing logic concerning the transformation of the received data to fit them into the BMM data model which will be the common language of the BMM network.

The adaptor pattern will ensure that the existing MSS systems need no mandatory modifications in order to be integrated into BMM.

5.1 XMSN Primary Nodes Web Services Definitions

The XMSN shall implement the following Service methods through the protocol stack described above.

[Req. 5.1] In order to demonstrate the target level of interoperability within XMSN, each Node shall define and implement the appropriate service meta-data (in terms of WSDL and XSD) according to the established requirement and the Data Model defined in §6.

5.1.1 [Req. 5.2] Track Data & Information Exchange Service – Web Services Definitions

5.1.1.1 Service Overview

	This document belongs to BlueMASSMED project's Partners. Any copy or use is forbidden without a prior written authorisation.	

The following figure gives an overview of the Track Data & Information Exchange Service.

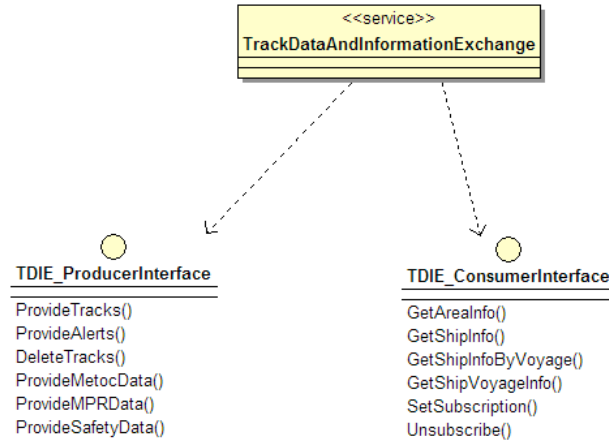

The availability for the XMSN of meteorological, pollution and safety still needs to be confirmed; thus the corresponding elements of the service’s interfaces are also to be confirmed.

5.1.1.2 Service Operational Concepts

The Track Data and Information Exchange Service operational concepts could be summarized by the following dynamic view which illustrates exchanges between service’s producer and consumer.

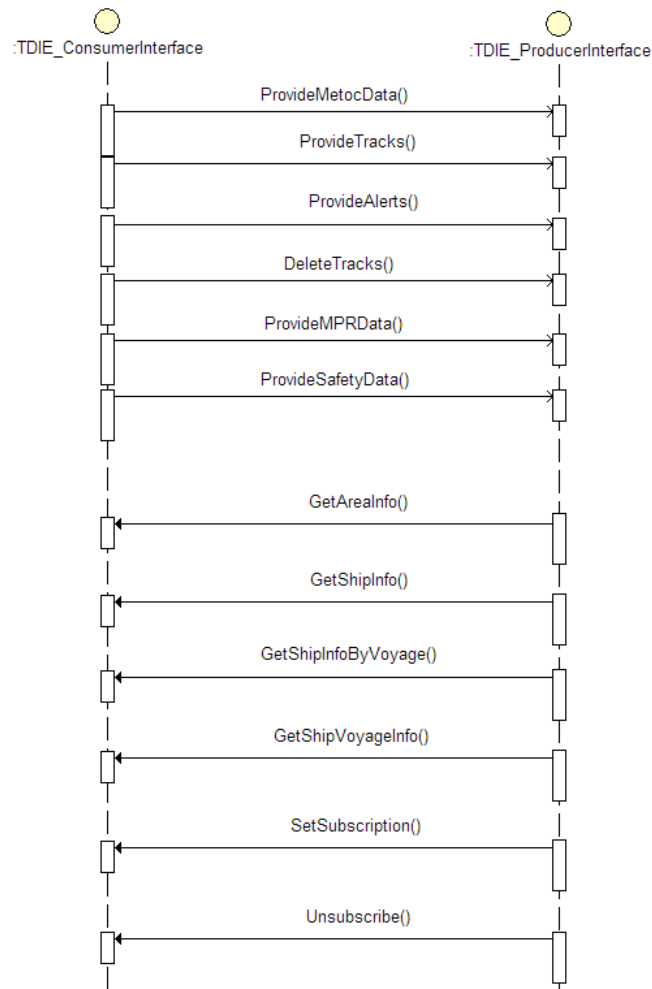

The following use-case diagrams describe the sequence of events in two exchange during a request-response mode (synchronous) and a simple publish and subscribe mode (asynchronous).

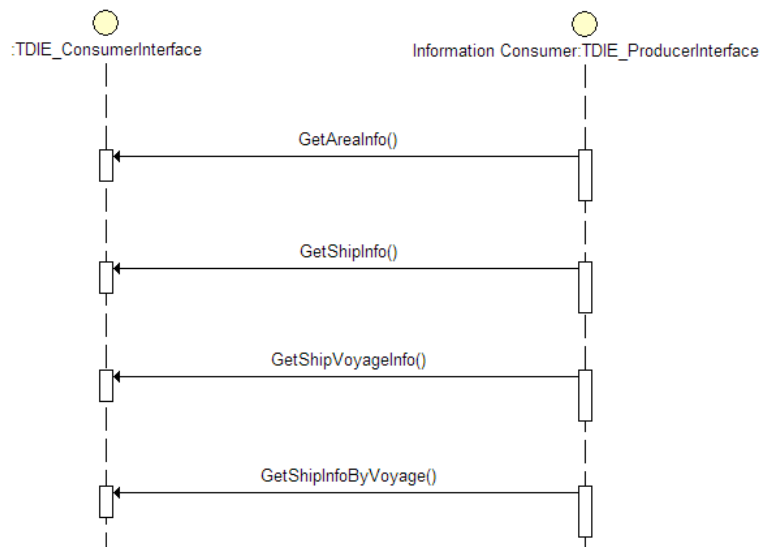

Exchanges between an information consumer and the service in a request-response mode

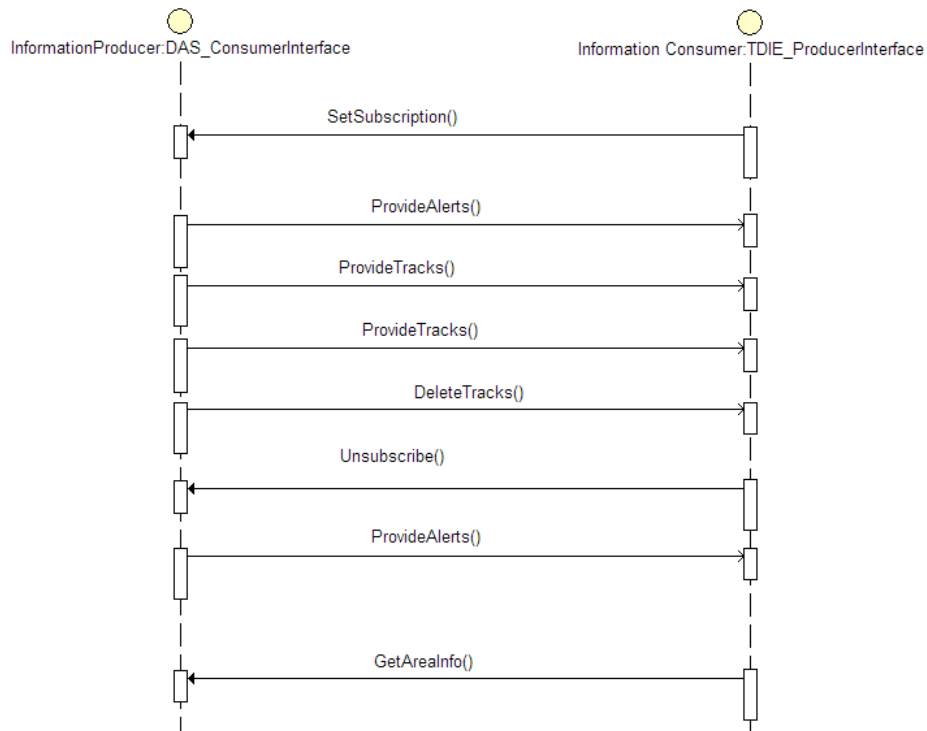

Exchanges between an information consumer and the service in a publish&subscribe mode

The following sections describe the methods that the Track Data & Information Exchange Service shall entail.

5.1.1.3 Consumer Interface Methods Description

The proposed mandatory parameters are highlighted in blue.

GetAreaInfo [areaOfInterest, notificationType, timeOfRequest, timeOfRequestEnd, timeOfRequestStart]

Output: [meteoNotification, trackNotification, voyageNotification, meteo, polrepNotification, safetyNotification, sitrepNotification, wasteNotification, otherNotification, hazmatNotification, foundLostContainers, topicNotification]

Tracks includes BASIC ID Data, POSITIONAL DATA, Static Track Data, Time Of validity

Voyage includes Position Vector, Basic Voyage Data, BASIC ID data, Time Of Validity

Meteo includes METOC Data

Polrep and other includes MPR Data

Safety includes Safety Data

	This document belongs to BlueMASSMED project's Partners. Any copy or use is forbidden without a prior written authorisation.	
--	--	--

Sitrep includes reports on ships (i.e. cargo manifest)

On request of the Service Consumer, the service provider shall transmit to the service consumer the track information at a certain time in an area of interest.

- GetNotificationInfo ()

Output: [notificationType]

- GetShipInfo [ship, timeOfRequest, trackNotification, shipId]

Output: [trackNotification, ship]

Tracks includes BASIC ID Data, Positional Data, Time Of validity

Ship includes ship static data

The service requests to the BMM Node track information at a certain time on an identified track, providing at the same time the best known information by the requesting node on the same track at the last time of validity.

-
- GetShipInfoByVoyage [ship, ShipID, Time_of_request, voyageNotification]

Output: [trackNotification, ship]

Tracks includes BASIC ID Data, Position Data, Time Of validity

Ship includes ship static data

The service requests to the BMM Node track information at a certain time on an identified track, providing at the same time the best known information by the requesting node on the same track at the last time of validity and the vector of the hystorical positions at their historical time of validity.

- GetShipVoyageInfo [ship, ShipID, Time_of_request, voyageNotification]

Output: [ship, voyageNotification]

Ship includes ship static data

- Voyage includes Position Vector, Basic Voyage Data, BASIC ID data, Time Of Validity

The service requests to the BMM Node the history of track information at a certain time on an identified track, providing at the same time the best known information by the requesting node on the same track at the last time of validity.

- GetTrackCount [areaOfInterest, timeOfRequestEnd, timeOfRequestStart]

Output: [trackCount]

5.1.2 [Req.5.3] Regional Track Correlation Service – Web Service Definitions

5.1.2.1 Service Overview

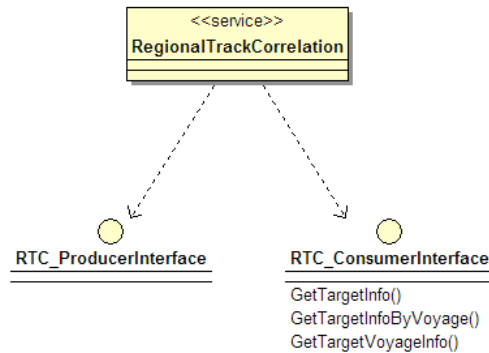

5.1.2.2 Service operational concepts

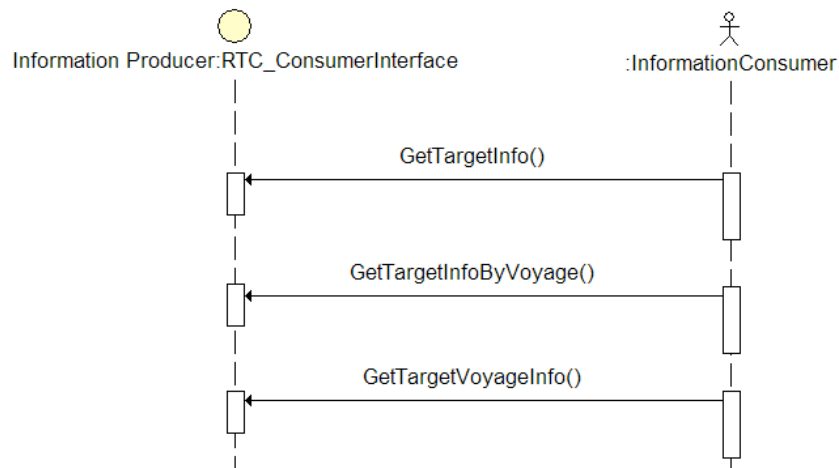

5.1.2.3 Consumer Interface Methods Description

The Regional Track Correlation Service shall entail the following methods:

- **GetTargetInfo(timestamp, position:trackNotification, timeOfRequest:dateTime)**
- **Output: [timestamp, confidence:ConfidenceType, lastPosition:TrackNotification]**

The service requests to the BMM Node correlating information at a certain time on an unidentified track, providing at the same time the best known information by the requesting node on the same track at the last time of validity, and gets the correlated data plus a confidence indicator as output.

- **GetTargetInfoByVoyage(timestamp, timeOfRequest, voyage)**

Output: [timestamp, confidence, voyage]

Voyage includes Position Vector, Basic Voyage Data, BASIC ID data, Time Of Validity

The service requests to the BMM Node correlating information at a certain time on an unidentified track, providing at the same time the historical position information on the same track and the related vector of time of validity, and gets the correlated data plus a confidence indicator as output.

- `GetTargetVoyageInfo(timestamp, lastKnowPosition)`

Output: [timestamp, confidence, voyage]

The service requests to the BMM Node historical information correlating at a certain time with an unidentified track, providing at the same time the best known information by the requesting node on the same track at the last time of validity, and gets the correlated data plus a confidence indicator as output.

5.1.3 [Req.5.4] Wide Area Rapid Mapping Service – Web Service Definitions

5.1.3.1 Service Overview

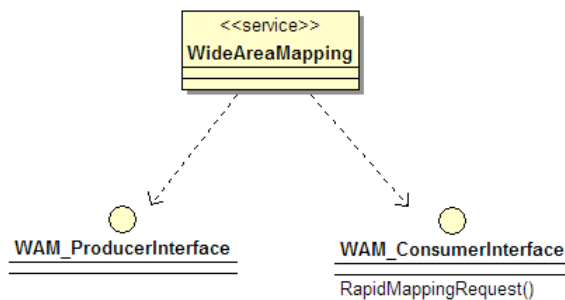

5.1.3.2 Service operational concepts

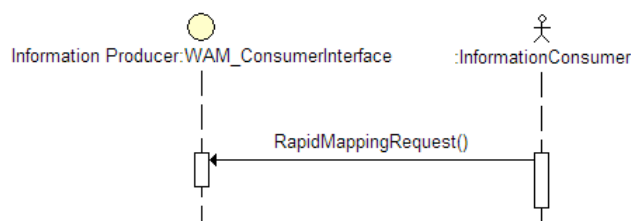

5.1.3.3 Consumer Interface Methods Description

The Wide Area Rapid Mapping service shall entail the following methods:

	This document belongs to BlueMASSMED project's Partners. Any copy or use is forbidden without a prior written authorisation.	
--	--	--

```
GetAreaRapidMapping(timestamp, areaOfInterest, imageType, maximumAge, maximumDeliveryTime, trackOfInterest)
```

```
Output: [timestamp, requestAccepted, expectedTimeOfDelivery]
```

```
ProvideAreaRapidMapping(timestamp, available, reason, imageUrl, swath, timeOfAcquisition, timeOfValidity)
```

```
Output: [timestamp, status]
```

The service requests to the BMM Node rapid mapping of an Area of Interest or over a Track of Interest, with a given Image_Type, a given maximum age and a given delivery time. The Output shall return the Image header (Swath, type) as soon as the image is ready or scheduled, or an error message if the image cannot be retrieved in due time.

The actual transfer of Raster, Vector and Satellite Maps shall occur through file transfer according to WMF and WGF standards

5.1.4 [Req.5.5] Data Augmentation Service – Web Service Definitions

Nota : Needs to modify figure 2.2 (FR unable to do it)

5.1.4.1 Service Overview

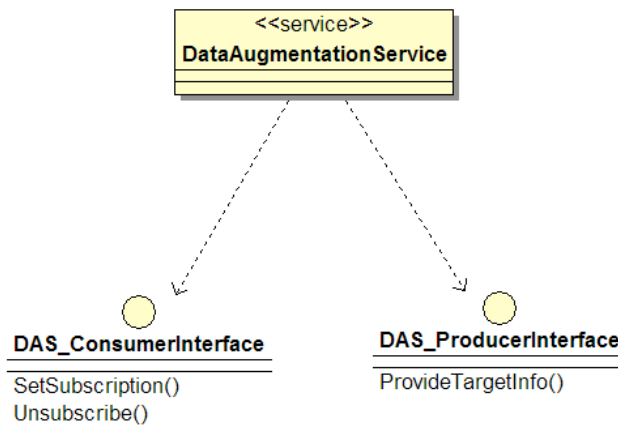

The Data Augmentation Service will provide access additional information regarding a BMM Track designated by its name, IMO number, Track number or MMSI number.

5.1.4.2 Service operational concepts

As defined in the basic requirements of the CCTP, the consumer node can request additional target information by using a subscription process.

The providing node will send updates regarding track information in an asynchronous way until it receives an unsubscribe message from the requester.

This principles are illustrated in the following figure.

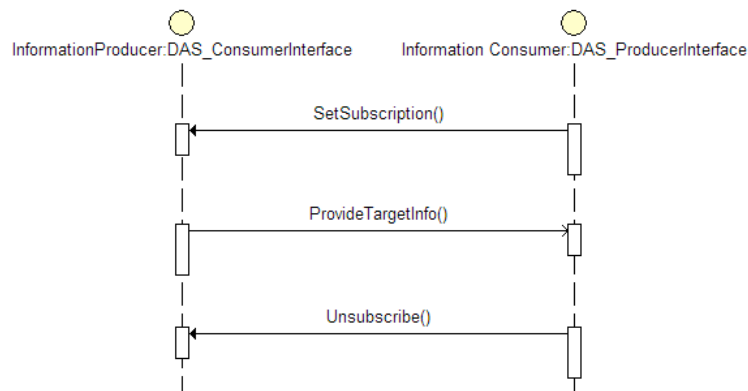

5.1.4.3 Consumer Interface Methods Description

SetSubscription (timestamp, topicId, areaOfInterest, xpathFilteringExpression, wsLocation)

Output: [SubscriptionId, success]

The service consumer subscribes to the BMM Node additional sectorial information providing the shipID.

Acces to the information depends on the requester credentials (to be confirmed).

Unsubscribe(timestamp, SubscriptionId)

Output: [success]

The service consumer stop the service request regarding the given shipID and subscriptionID.

5.1.4.4 Producer Interface Methods Description

ProvideTracks (timestamp, subscriptionId, urls, tracks)
Tracks includes BASIC ID Data, Positional Data, Time Of validity

Output: [return]

ProvideMeteoNotification (timestamp, subscriptionId, urls, notification)
Notification includes METOC Data

Output: [timestamp, return]

ProvidePOLREPNotification (timestamp, subscriptionId, urls, notification)

Output: [timestamp, return]

ProvideSafetyNotification (timestamp, subscriptionId, urls, notification)

Output: [timestamp, return]

6 BMM DATA STRUCTURES (SV-11)

The BMM Data Model defines the data classes and structures that shall be used within web-services specifications, xml interfaces and internal BMM Node data format, in order to ensure interoperability within the network.

The main data types have been defined in the CCTP during the study phase (see Appendix 2 SOV-2) and are grouped in the following classes:

- Positional Data
- Basic Current Voyage Data
- Basic ID Data
- Historical Data
- Other Ship Related Data
- Time Data
- Area Data
- Image Data

These data are mainly related to ships but not only, and comprises as well meteorological information, safety data, pollution information, etc. Please consult the CCTP Appendix 2 for a complete list of data fields.

6.1 BMM XMSN Reduced Data Structures

In order to reduce the complexity of the BMM demonstrator XMSN, and taking into account the Data Models already developed in other contexts (eg PT MARSUR), a reduced Data Model is proposed for utilisation at XMSN level. Such Data Model is adapted from the PT MARSUR Data Model, adding the service-based data exchange logic which distinguishes the BMM approach.

[Req.6.1] The BMM XMSN Demonstrator shall implement the following reduced Data Structure.

Group	No (ref.to CCTP)	Information	Data Type
Positional data	1	Track number or label	string
	2	Position latitude and longitude	decimal
		Altitude	decimal
	3	Time GMT	dateTime
	4	Course	decimal
	5	Speed	decimal
	6	Navigational status	string
	7	Type of sensor	string
	8	Data provider	string
Basic Current voyage data	14	Port of destination	string
	15	Time of Arrival (ETA +ATA)	dateTime
	18	Draught	decimal
BASIC ID Data	27	Name	string
	34	Length	integer
	38	Width	complex type integer
	40	Flag	complex type string3

Group	No (ref.to CCTP)	Information	Data Type
	43	IMO number	union of string integer7
	44	MMSI number	Union of long and string integer9
	29	Ship Type	string
	45	International Radio Call Sign	string
		Ship ID	
		Track Static Data	
Other data	57	Pointer to Satellite Imagery	
	61	Alerts on track	Union of integer and string
		METEOCData	
		SafetyData	
		MPRData	
		Confidence_Type	
		Classification	string
Time data		Simulated Object	integer
		Time of Validity	dateTime
		Time of Request	dateTime
		Time of Delivery	
Area data		Time of Availability of Sat Image	dateTime
		Area of Interest	integer
Image data		Swath	
		Image Type	
		Image Resolution	
		Image Time of Acquisition	
		Image Swath	
Subscription data		Maximum Age	
		SubscriptionID	

The following variable declarations are applicable to the WSDL specifications reported in the §5.

```

Area_of_Interest    ::      Area
Time_of_Request     ::      Time
ShipID              ::      Name // IMO Number // MMSI // CallSign // Flag
Time_of_Validity    ::      Time
Track_Static_Data   ::      Current Basic Voyage Data + Basic ID Data + Other Data
Position_Data       ::      Positional Data
Confidence          ::      Confidence_Type
Image Type          ::      Image Type
Maximum Age         ::      Image Time of Acquisition
Delivery Time       ::      Time
Swath               ::      Area
  
```

The Data Format shall be completed in terms of XSD.

Data Model Traceability Matrix System View vs wsdl

SYSTEM VIEW DATA	TRACED BY	SYSTEM VIEW DATA	TRACED BY
Basic Current Voyage data	VoyageNotification	Time Of Validity	TrackNotification VoyageNotification
Positional Data	TrackNotification	Time Of request	TimeOfRequestEnd TimeOfRequestStart Timestamp
BASIC ID Data	TrackNotification VoyageNotification	Area Of Interest	Area
TrackNumber	TrachNotification	Image Type	ImageType
Position	TrackNotification VoyageNotification	ShipID	TrackNotification VoyageNotification ShipID
Altitude	TrackNotification	Time_of_Validity	VoyageNotification
Time GMT	TrackNotification	Track_Static_Data	TrackNotification VoyageNotification ShipID Ship
Course	TrackNotification	maximumAge	maximumAge
Speed	TrackNotification	DeliveryTime	maximumDeliveryTime
NavigationalStatus	TrackNotification	METEOCdata	MeteoNotification
Type Of Sensor	TrackNotification	SafetyData	SafetyNotification
Data Provider	TrackNotification	MPRData	POLREPNotification
Port Of Destination	VoyageNotification	SubscriptionID	SubscriptionID
Time Of Arrival	VoyageNotification	Flag	VoyageNotification
Draught	VoyageNotification	IMO number	VoyageNotification
name	VoyageNotification	MMSI number	VoyageNotification
Length	VoyageNotification	Ship Type	VoyageNotification
Width	VoyageNotification	CallSign	VoyageNotification
Confidence Type	ConfidenceType		

7 BMM QUALITY REQUIREMENTS DESCRIPTION (SV-7)

Following the BMM Pilot Project approach, SV-7 initial draft is referred only to the subset of services that will be implemented on the BMM XMSN demonstrator.

Accordingly, SV-7 will be incremented along the project to reach the full scale BMM EMSN, taking into account the lesson learnt of BMM demonstrator.

The goal of BMM Core Services is to provide essential services for assuring the correct operation of the BMM network and good connectivity and flexibility of cooperation among the connected nodes.

It means that quality requirements on Core Services will not be defined, because they are implicit in the QoS of Common Services.

[Req.7.1] The following table correlates the measure of success of XMSN Common Services with the Quality Requirements that apply to the BMM XMSN demonstrator environment.

Service	Measure of Success	Quality Requirement
Regional track correlation service	<p>Maximum number of tracks</p> <p>Timing for data availability (time period from the service request to the service provision)</p> <p>Source data type (AIS, LRIT, VMS, etc.)</p> <p>Track streaming update time</p> <p>Detection and Classification Capabilities</p>	
Wide Area Rapid Mapping service	<p>Covered Area</p> <p>Timing for data availability (time period from the service request to the service provision)</p> <p>Satellite Scheduling Capabilities</p> <p>Type of Satellite Imagery</p>	

ANNEX I PROCEDURE FOR THE ESTABLISHMENT OF THE SHARED BASIC COMMON MARITIME PICTURE (SBCMP)

According to the established objectives, the BlueMassMed project shall conduct a demonstration of a shared basic common maritime picture (SBCMP) updated on a near real time basis, provided by the inter-connection of national systems (existing or under development) and the experimentation of simulated data exchanges in liaison with chosen scenario (e.g. terrorist threats, illegal immigration, pollution, etc.).

In addition, within the project, the SBCMP will be enhanced by simulated sensitive data to be exchanged between interested and cleared partners.

HARMONISED REQUIREMENTS FOR THE ESTABLISHMENT OF THE SBCMP

Primary Nodes in the BMM network, participating to the establishment of the SBCMP, shall implement the basic procedure depicted in Fig. 1 and shall respect the following implementation requirements.

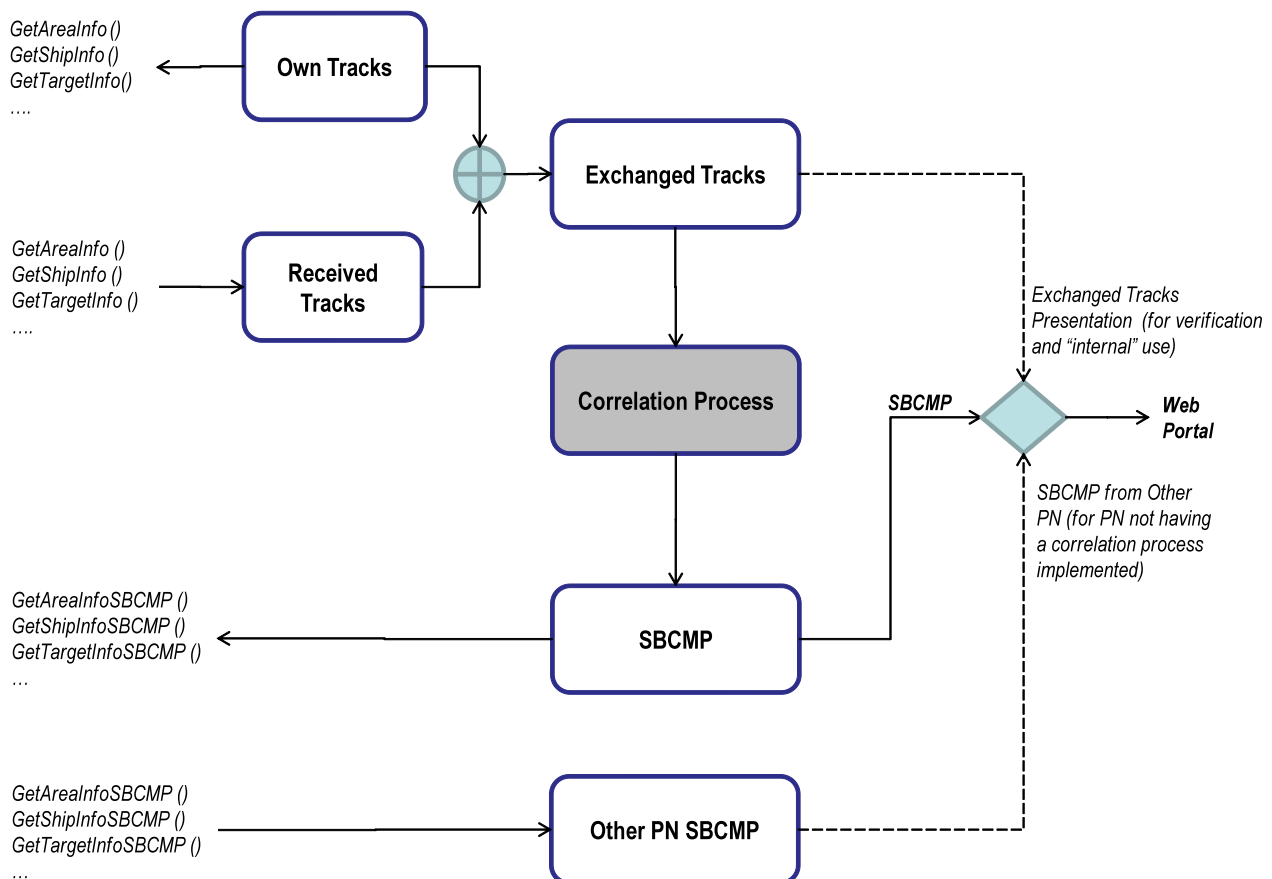

Fig. 1 – Basic Procedure for SBCMP establishment (NSV-12)

A. BASIC TRACK EXCHANGE HANDLING

	This document belongs to BlueMASSMED project's Partners. Any copy or use is forbidden without a prior written authorisation.	

1. Tracks received by a PN from its back-end shall be promoted to the status of “**SBCMP tracks**” through conversion to the BMM Data Model as defined in the SV.
2. Tracks promoted to the SBCMP shall have:
 - a. an unique SBCMP identifier of the form *PN_nnnn (IT_000001, PT_000001, SPA_000001, SPG_000001, etc.)* (field *1_Track_Number_or_label*)
 - b. a time stamp with the time of validity of the last measurement or of the last PN specific processing (field *3_Time GMT*)
 - c. a track origin indicator marked as:
 - field *7_Track Source (ordered by increasing nominal accuracy)*
(0-Unknown, 1-Other ShipRep, 2-AIS, 3- LRIT 4-SAR, 5-Radar, 6-Intel, 7-Visual)
 - field *8_Data Provider*
(0 – Scenario Fake Track, 1-999 Agency Code *TBD* by *UWG*)
 - d. a data classification level:
 - field *XX_Data Sensitivity Level*
(0 – Basic, 1 –9 Sensitivity Level 1..9 *TBC*)

Note: as a simplification for the XMSN implementation it shall be assumed that the Data Classification level assigned to each single track shall apply to all the “non-basic” data fields contained in the track (according to the BMM OV)
 - e. a track data nature:
 - field *XX_Simulated Object*
(0 – Real Object, 1 – Simulated)
 - f. a confidence indicator:
 - field *XX_Confidence Type*
(according to User Requirements)
1 = very high confidence, verified data,
2 = high confidence (cooperative / non cooperative correlation),
3 = confident (non coop / non coop correlation or coop/coop correlation)
4 = low confidence (unsure source of verification, low confidence correlation)
5 = very low confidence (no verification, co-operative target *TBC*)
3. Tracks generated by each PN (tracks with identifier NN=Own PN) are sent to the other PNs through the defined common services *GetAreaInfo()*, *GetShipInfo()*, *GetTargetInfo()*, etc..
4. Tracks generated by other PN (tracks with identifier NN not= Own PN) are received by each PN through the defined common services *GetAreaInfo()*, *GetShipInfo()*, *GetTargetInfo()*, etc..

B. CORRELATION PROCESS

The Basic Correlation Process Scheme is reported in the Fig. 2 below.

	This document belongs to BlueMASSMED project's Partners. Any copy or use is forbidden without a prior written authorisation.	
--	--	--

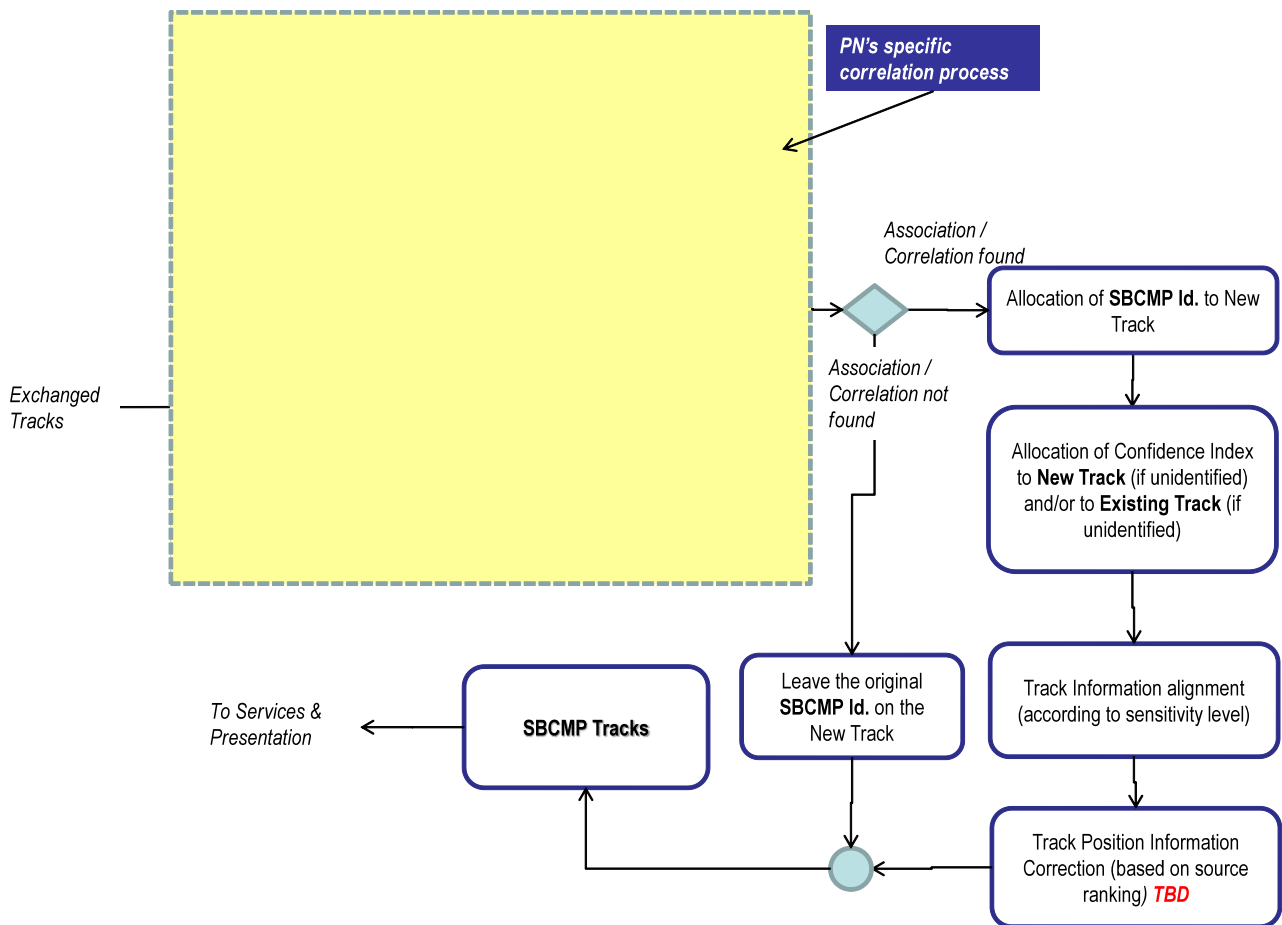

Fig.2 – Correlation Process Scheme (NSV-12)

The following requirements apply:

1. All exchanged tracks are processed at regular intervals, variables according to the operational needs (e.g. from 1 to 10 min) by each PN in order to establish the potential association/ correlation and solve conflicts in areas of overlapping
2. For any group of tracks having the same SBCMP identifier, only one correlation processing shall be performed using the track with the most recent time of validity.

Such correlation processing shall include performing association/correlation tests w.r.t. all the other tracks having a different SBCMP identifier and a position, reported at the same time of validity of the processed track, falling within an area of radius R_{min} from the processed track.

3. Tracks that are not associated nor correlated (based on space-time and/or basic_Id criteria) are only processed by time normalisation for visualisation purposes, and are not modified throughout the Correlation process and keep their original identifier.
4. Tracks showing association of *Basic_Id* parameters and/or time-space correlation of relevant positional data and/or motion parameters beyond a defined threshold, shall be processed according to the following steps:

	This document belongs to BlueMASSMED project's Partners. Any copy or use is forbidden without a prior written authorisation.	
--	--	--

- The SBCMP identifier of the track with the older validity time shall be assigned to all correlated/associated tracks
- All data fields that are void in one track (except positional data) shall be updated with data fields present in the associated/correlated tracks having lower classification level; in case of conflicts among these data fields, the one present in the track with higher Track_Confidence shall be used and a “Data Conflict” Alert shall be raised on the track.
- The positional data missing in each of the tracks (if any) is updated using the known positional data of the associated / correlated tracks (regardless classification level)
- In case the times of validity of the correlated / associated tracks are closer than 30 seconds, the positional data and time of validity of all those tracks shall be aligned using the positional data and time of validity of the track with higher *track_source* indicator, and in case of ambiguity, the most recent time of validity
- The confidence indicator of the associated /correlated tracks is modified according to the following rules:

Confidence before correlation	Confidence after association with a very high confidence track	Confidence after association/correlation with a track from an alternate source (cooperative / non cooperative)	Confidence after association/correlation with a track from the same source (cooperative / non cooperative)
1	1	1	1
2	1	2	2
3	1	2	3
4	1	2	3
5	1	4	4

C. DISTRIBUTION OF SBCMP TRACKS

1. SBCMP tracks are distributed through a dedicated WS (SBCMP_tracks_exchange) including the two dedicated methods GetAreaInfo_SBCMP() and GetShipInfo_SBCMP().
2. The Basic data, accessible to all Users, are designated by the *classification_level=0*. Access to tracks with sensitivity level>0 shall be allowed through the associated Service Authorisation logic (DDP filtering).
3. The SBCMP tracks (basic + sensitivity levels) are presented on the web portal / webgis with a multi-layer structure for use by authorised secondary nodes.

PN SPECIFIC CORRELATION LOGIC

Each PN’s shall be responsible of implementing his own correlation algorithms and logics. However, in general it is expected that the association / correlation process shall comprise the following steps:

1. Time Normalization

	This document belongs to BlueMASSMED project's Partners. Any copy or use is forbidden without a prior written authorisation.	

Since in a regional monitoring systems exchanged tracks can be transmitted with very different time base (periodicity and offset), Time Normalisation is needed to align all SBCMP tracks on a common time base primarily for visualisation purposes.

The function shall translate by dynamic propagation the received track data on the reference time base of the receiving PN, based on the received track motion parameters and time of validity.

2. Tracks Association

This function shall identify existing tracks which have at least one of the Universal Ship Id parameters (Ship Name, Ship IMO Number, Ship MMSI, International Call Sign) identical.

Regardless of the time of validity and position / speed parameters of such tracks, an association and back/forward tracking process shall be implemented in order to bridge the positional gap between associated tracks measurements.

In case an inconsistency is detected among the Ship Id data and the positional data compatibility, a “Data Inconsistency” Alert shall be raised on the involved tracks.

3. Tracks Correlation

The correlation function shall evaluate the correlation level at a certain time of validity between tracks which cannot be associated on the base of their Universal Ship Id parameters. This may be implemented through calculation of the geometric and/or statistic distance among tracks in a space/time domain, and comparing with a pre-defined threshold.

Specifically the correlation function shall at least:

- Perform backward or forward motion prediction (on the terrestrial ellipsoid) on the involved tracks, up to the correlation time instant;
- Calculate a correlation index between the involved tracks at the correlation time instant, based on the respective kinematics and motion parameters; in case of availability of track history, additional parameters such as the tracking filter parameters and the track measurement accuracy can be exploited for the determination of the correlation index;
- Compare the correlation index with suitable thresholds in order to decide whether or not a correlation is declared.

TRACEABILITY TO USER AND SYSTEM REQUIREMENTS

Main User Requirements

Requirement	Compliance
[BMM.DER.01] The BMM system shall allow partners to exchange data to set up a situational awareness in the sea, from the Western Approaches to the Strait of Gibraltar to the east of the Mediterranean Sea establishing a Shared Common Basic Maritime Picture (SCBMP).	§1, §2 Note: the SBCMP is established by each Node according to harmonised rules but specific algorithms
[BMM.DER.03.06] Every track in the system shall have an unique identifier.	§1.A.2.a, §1.B.3
[BMM.DER.04] BMM shall allow nodes to manage track correlation including at least:	
[BMM.DER.04.01] BMM shall allow users to correlate tracks.	§1.C (Users can access to correlated tracks)
[BMM.DER.04.02] Every track distributed in the system shall contain an attribute indicating if it is a correlated track.	§1.C (In XMSN there will be independent access to exchanged tracks after correlation process)
[BMM.DER.04.03] A BMM node shall be able to automatically correlate tracks under established conditions and rules.	§1.B.1
[BMM.DER.04.04] Tracks correlated in a BMM node could be published to other nodes under user decision or due to automatic filtering.	§1.C
[BMM.DER.04.05] BMM shall allow nodes to establish filters in subscriptions, so that only correlated data is sent.	§1.C (In XMSN there will be independent access to exchanged tracks after correlation process)
[BMM.DER.13] The last valid measurement time must be indicated in the transmission of the exchanged data.	§1.A.2.b
[BMM.DER.14] A confidence value shall be allocated to the exchanged information: 1 = high confidence, verified data 2 = high confidence 3 = confident 4 = low confidence, unsure source of verification 5 = very low confidence, no verification, co-operative target	§1.A.2.f

<p>[BMM.DER.15] A quality value shall be allocated to the exchanged information.</p>	<p>§1.A.2.c (Track quality will be linked to a combination of origin+confidence)</p>
---	---

Main System Requirements

Requirement	Compliance
<p>[Req.4.32] The TM function shall exchange track data over point-to-point (or local SOA) interfaces with Nation-specific legacy systems, and shall adapt the exchanged data to the BMM data model.</p>	<p>§1.A.1, §1.A.2</p>
<p>[Req.4.33a] The TEX function shall perform the basic operations supporting the exchange of track data among BMM nodes:</p> <ul style="list-style-type: none"> • Receive and handle the Local or Remote Users requests of services concerning track exchange • Follow-up on-going services requests • Process received BMM tracks from other nodes and extract the track data according to the BMM data model, storing the track data into the Node Track Temporary Data Base • Execute the necessary functions according to the requesting services and involving the TS and TAC functions (see §5.5) • Prepare BMM tracks for transmission to requesting nodes, according to the BMM data model, retrieving the track data from the Node Track Temporary Data Base 	<p>§1.A, §1.B</p>
<p>[Req.4.34] The TSAC function shall perform the basic operations supporting:</p> <ul style="list-style-type: none"> • synchronisation of tracks known different time of validity • association of tracks (i.e. based on static or semi-static parameters matching) • correlation of tracks, meaning the association of partially unknown tracks on the base of dynamic (kinematic) parameters matching. 	<p>§1.B, §2</p>
<p>[Req.4.34a] The TSAC Synchronisation function shall be capable to align the input track data to a common reference time instant, implementing standard prediction algorithms or, if necessary to recover large synchronisation gaps, back propagation and forward propagation algorithms.</p>	<p>§2.1</p>
<p>[Req.4.34b] The TSAC Association function shall be capable to associate input and own tracks presenting a firm matching in static or semistatic parameters like MMSI, IMO Number, Ship Name and Call Sign, etc. The association function shall mark associated tracks as such, and merge them if requested. A suitable logic shall be applied to handle discrepancies in associated tracks data, based on the trustworthiness and accuracy of the respective origin.</p>	<p>§2.2</p>

<p>[Req.4.34c] The TSAC Correlation function shall be able to correlate input tracks with own tracks matching in dynamic parameters like position / course / speed and their expected predictions / propagations, defining and assessing a confidence index of the correlation that will be used to indicate the usability of the correlation results.</p> <p>The correlation can be based on a mix of deterministic, statistical methods as well as on adaptive tracking techniques, taking into account the specific characterisation of the different targets and a maximum time span among the tracks to be correlated up to several hours.</p>	<p>§2.3</p>
<p>[Req.3.5] At each BMM Primary Node, when an authenticated BMM user asks to invoke a BMM service, a Service Authorization procedure shall look-up the DDP to find the restrictions and / or limitations to the access of the requesting User to services and data, as option, according to its credentials.</p>	<p>§1.C.2</p>
<p>[Req. 3.6] The restrictions and limitations of access to the BMM services and data shall consist of:</p> <ul style="list-style-type: none"> • Denied access to one specific BMM service (S1,...S6); • Denied access to the different groups of Data Packages (Basic / Sensitive); • Denied access to specific types or classes of tracks (by query on BASIC_ID_DATA) • [Optional] Limitations in access on specific track data fields (Basic_ID_Data, Basic_Voyage_Data, Historic_Data, Other_Data). 	<p>§1.B.3</p>

IMPACTS ON DATA MODEL & COMMON SERVICE SPECIFICATIONS

The following impacts shall be taken into account on the Data Model specifications due to the implementation of the SBCMP requirements (see modifications in red).

Group	No	TAG	Modifications on Data Type	
	(ref.to CCTP)			
Positional data	1	Internal Track Number		
		Position	Complex type	Latitude Longitude Altitude
	7	Type of sensor	enumerated	0-Unknown, 1-Other ShipRep, 2-AIS, 3-LRIT 4-SAR, 5-Radar, 6-Intel, 7-Visual
	8	Data provider	enumerated	0 – Scenario Fake Track, 1-999 Agency Code
BASIC ID Data		SBCMP_ID	string	“PN_Id + nnnnnn” PN_Id = IT, FR, SPA, SPG, PT, MT, GR nnnnnn = from 000000 to 999999
		bmmShipGuid	string	
	new	ShipId	Complex Type	SBCMP_ID MMSI number Name IMO number Call Sign
OTHER Data	61	Alerts on track	enumerated	Alert Code 999: “Data Inconsistency Detected” Alert Code 1-998: TBD
		Confidence_Type	enumerated	1 = very high confidence, verified data, 2 = high confidence, 3 = confident, 4 = low confidence, 5 = very low confidence
	not included	Simulated Object	enumerated	0 – Real Object, 1 – Simulated
	new	Data Sensitivity Level	enumerated	0 – Basic, 1 –9 Sensitivity Level TBC

The following new Service is introduced:

SBCMP_Tracks_Exchange Service

Including the following two operations:

GetAreaInfo_SBCMP(timestamp,areaOfInterest,timeOfRequestEnd,timeOfRequestStart, sensitivity_level)

Output:[timestamp, tracks, voyages, meteo, polrep, safety, sitrep, waste, other]

The service will provide all the ship information available in the SBCMP in the area of interest with time of validity included in the specified time window, and with sensitivity level up to the specified level (if authorized).

GetShipInfo_SBCMP(timestamp, Ship_ID, Time_of_request, sensitivity_level)

Output: [timestamp, track, ship]

The service will provide information available on a single ship within the SBCMP at the request time of validity, and with sensitivity level up to the specified level (if authorized). The ship can be identified by its universal identification (if MMSI, IMO Number, Name, Call Sign are known) and/or by its SBCMP Id alone, if the universal identifiers are not known.

The Input and output parameters are mapped to the data model specifications according to the following table, which is fully in line with currently implemented wsdl (v.1.2.1 and 1.2.0)

Type	Data Model	Type	Data Model
Track	Track number or label	Voyage	shipId
	shipId		Time of Validity
	position		Position + Time of Validity [0..*]
	Time		Draught
	Course		Port of Departure
	Speed		Time of Departure
	Rate of Turn		Port of Destination
	Navigational Status		Time of Destination
	Type of Sensor	Ship	Ship Id
	Data Provider		ISPS code
	Alerts on Track		Flag
	Confidence Type		Ship Type
	Simulated Object		Ship Crew
	Data Sensitivity Level		Lenght
			Ship Photo
			Other data

ANNEX II TRACK CORRELATION ALTERNATIVE SOLUTION

1 SHARED BASIC COMMON MARITIME PICTURE (SBCMP)

a. SBCMP is defined as the picture resulting from all the tracks that the Primary Nodes have decided to exchange and the sifting of R². Each object normally will be reported by one Node while other Nodes withhold their reports to prevent cluttering the SBCMP. Determination of the Node responsible for reporting the object shall be in accordance with the procedures in section 2. A track for which positional data has been locally derived by a Node but is currently being reported by another Node is referred to as a "common local track", and a track for which positional data has been locally derived and is not currently being reported by another Node is referred to only as a "local track". In order for SBCMP to function properly, all Nodes shall perform correlation and decorrelation of their local track data with respect to the remote data which they are receiving. Failure to properly correlate can result in a dual designation. The protocols in this document are to be followed in order to minimize occurrences and duration of dual designations.

b. Each Node which has a capability to originate and report tracks shall have a capability to perform SBCMP in accordance with the correlation and decorrelation procedures and criteria which follow.

1.1 Track Correlation. The correlation process commences with comparing locally derived sensor data (position, velocity, IMO number and MMSI number) with the data received on the BMM Network, in order to prevent or eliminate dual designations. All Nodes that originate tracks shall have an automatic correlation capability. The following subparagraphs apply to the correlation of any two tracks unless otherwise specified.

a. Local Correlation. The method used for internal correlation of local sensor data is a system design option, irrespective of any of the rules herein.

b. New Local Tracks for SBCMP. New local tracks shall not be reported to the BMM Network until an automatic correlation has been attempted and failed on an initial correlation test or on the next test following an initial tentative correlation (see subparagraph 1.1h). If no tentative correlation is found on the initial test, the new local track shall be transmitted. If the new local track tentatively correlates on the initial test but fails correlation on the next test, the new local track shall be transmitted. A new local track that correlates with another track on each of the first two correlation tests shall be correlated and held as a common local track. Thereafter, the decorrelation rules (see paragraph 1.3) apply to the track. If an operator

	This document belongs to BlueMASSMED project's Partners. Any copy or use is forbidden without a prior written authorisation.	

action has been taken which selectively released a new local track for reporting, it shall be transmitted, regardless of the results of correlation testing.

c. Automatic Correlation.

(1) Nodes shall make an automatic correlation test upon receipt of each remote track which is not confirmed to have an existing correlation to a local track. Such tests shall compare the received remote track to local tracks, including previously common local tracks for which own unit has R².

d. Manual Correlation.

(1) A manual capability shall be provided to initiate the correlation of any two tracks irrespective of the correlation test criteria in subparagraph 1.1f or the requirements in subparagraph 1.1h. Manual correlation shall not be allowed for the following:

- (a) One track is simulated and the other is live.
- (b) Both tracks are remote.

e. Response to Correlation Request. Nodes shall perform correlation tests in response to correlation requests from other Nodes in accordance with the requirements.

f. Correlation Tests. Correlation testing shall consist of the IMO and NMSI numbers, position, and velocity tests specified in this paragraph. These tests are summarized in Table a and specified in detail in the remainder of this paragraph. Positions of all tracks tested for correlation shall be extrapolated to the same time. The correlation test shall occur no more than 6 seconds after the extrapolation time. A local track shall be considered to correlate to the closest remote track that meets all of the correlation tests, subject to the correlation restrictions and the requirement to pass two correlation tests.

Table a Summary of Correlation Tests

IMO and MMSI Numbers test
<p> IMO_R Flag = 0 if no data IMO_R Flag = 1 if data $MMSI_R$ Flag = 0 if no data $MMSI_R$ Flag = 1 if data If $IMO_R = IMO_L \rightarrow$ Same-IMO Flag = 1 If $IMO_R \neq IMO_L \rightarrow$ Same-IMO Flag = 0 If $MMSI_R = MMSI_L \rightarrow$ Same-MMSI Flag = 1 If $MMSI_R \neq MMSI_L \rightarrow$ Same-MMSI Flag = 0 </p>
Positional Test
<p> $D \leq [a \cdot \sqrt{L^2 + R^2} + b] dm$, where: </p> <p> D = Distance in dm between two tracks; a = "window size multiplier" parameter; $L = \min([\max(E(CT_L), E(d))], E(c))$; $R = \min([\max(E(CT_R), E(d))], E(c))$; $E(CT_L)$ = positional error associated with local track quality CT_L, from Table b; $E(CT_R)$ = positional error associated with remote track quality CT_R, from Table b; $E(c)$ = positional error associated with $CT = c$, "MIN CT" parameter, from Table b; $E(d)$ = positional error associated with $CT = d$, "MAX CT" parameter, from Table b; </p> <p> b = "minimum window size" parameter. </p>
Course Test
<p> If both tracks have speed ≥ 10 dmh: </p> <p> $\min(C_R - C_L , 360 - C_R - C_L) \leq f$, where: </p> <p> C_L = local course in degrees; C_R = remote course in degrees; f = "course differential" parameter; </p> <p> Otherwise course is not used in the correlation test. </p>
Speed Test
<p> $1 - S_S/S_F \times 100\% \leq \max(g, [g(k/S_F)])$, where: </p> <p> S_S = speed of slower track in dmh; S_F = speed of faster track in dmh; g = "speed differential" parameter; $k = 20$ dmh for surface tracks. </p>

(1) Correlation Test Prohibitions. The following shall not be tested for correlation:

(a) A track with $CT \leq e$ (see subparagraph 1.1f(2)). This prohibition does not apply to new local real-time tracks, but does apply to nonreal-time ($CT=0$) tracks.

(c) Simulated tracks with live tracks, and live tracks with simulated tracks.

(2) Variable Parameters. Variable parameters are used to specify the default, range, and increments of values to be used in correlation tests. They are expressed in the form "default (range, increment)". The intent is to enable rapid change of the standard correlation tests as experience and conditions dictate. Systems shall be capable of using any value within the specified range and increments upon system initialization, and shall set the parameter to the default value if no other value is specified. The variable correlation parameters are defined as follows:

- | | |
|----------------------------|---|
| a = 1.0(0.5-3.0, 0.1) | "Window size multiplier". Allows increasing or decreasing the standard CT-based window sizes to be used by all Nodes in an BMM Network. |
| b = 0.5(0-2.0, .25) dm | "Minimum window size". A value applied to all calculated windows to insure that windows are not so small as to prevent valid correlations, e.g., due to minor errors introduced by extrapolation. |
| c = 7(3-7, 1) | "Min CT". The minimum CT to be used in positional correlation calculations. Lower CTs shall be treated as if they were c. This prevents correlation windows from being unrealistically large. Note: The value used for c can never be less than or equal to the value used for e. |
| d = 10(8-15, 1) | "Max CT". The maximum CT to be used in positional correlation calculations. Higher CTs shall be treated as if they were d. This prevents correlation windows from being unrealistically small. |
| e = 4(2-6, 1) | "Restricted CT". Tracks with CT less than or equal to e are not eligible for correlation, except for new local real-time tracks (see subparagraphs 1.1f(1)(a) and 1.1f(4)). |
| f = 45(15-90, 15) degrees | "Course Differential". The maximum difference between the reported course of the remote track and the calculated course of the local track allowable for correlation. If the speed of either track is less than 10 dmh, "course differential" shall not be applied in the correlation test. |
| g = 40(10-100, 10) percent | "Speed Differential". The maximum percentage by which the speed of the faster track may differ from the speed of the slower track for correlation. |

(3) IMO and MMSI Numbers test. Tracks shall be compared with all locally derived IMO and MMSI data, performing the following process:

If IMO_R and/or $MMSI_R$ Flags = 1, remote IMO and/or MMSI data shall be compared with local derived data:

- If no matched found, set Same-IMO and/or Same-MMSI Flag to 0
- If IMO and/or MMSI data matched on the same local track set Same-IMO and/or Same-MMSI Flag to 1
- If IMO matched and MMSI differs on the same track, set Same-IMO flag to 1, Same-MMSI flag to 0 and alert the operator
- If MMSI matched and IMO differs on the same track, set Same-IMO flag to 0, Same-MMSI to 1 and alert the operator
- If IMO and MMSI data matched on different local derived tracks, alert the operator

After performing all other correlation tests, perform the following:

- If the correlation is found and Same-IMO and/or Same-MMSI flags are set to 0, alert the operator
- If correlation is not found and Same-IMO and/or Same-MMSI flags are set to 1, alert the operator

(4) Position Test. Two tracks shall be eligible for correlation, subject to the other tests, prohibitions, and limitations of this paragraph, if they pass the following positional test:

$D \leq [a * \text{SQRT}(L^2 + R^2) + b]$ dm, where

D is the distance (in dm) between the tracks;

a = "window size multiplier" parameter;

b = "minimum window size" parameter;

L = Positional error associated with the CT of the local track (restricted by Min CT and Max CT); and,

R = Positional error associated with the CT of the remote track (restricted by Min CT and Max CT).

L and R are derived from the formula for the area of a circle, $A = p r^2$, with L and R equating to r, the radius of the circle. Thus, L (or R) = $\text{SQRT}(A/p)$, where A is the circular area in dm² within which it is assessed that there is a 95% probability that the track lies, as defined by Confidence_Type for the local (or remote) CT. Table b specifies the values of L and R for each CT.

Table b Positional Errors Represented by CT

	This document belongs to BlueMASSMED project's Partners. Any copy or use is forbidden without a prior written authorisation.	

CT	L, R
15	0.003 dm
14	0.006 dm
13	0.01 dm
12	0.02 dm
11	0.05 dm
10	0.10 dm
9	0.59 dm
8	1.18 dm
7	2.93 dm
6	5.92 dm
5	8.87 dm
4	11.82 dm
3	14.78 dm
2	29.61 dm

(5) CT Limitations. Tracks with CT less than or equal to the restricted CT value e shall not be automatically correlated, since their positional accuracy is not sufficient to support valid correlation decisions. Furthermore, the range of CTs used in determining correlation windows may be limited, since use of lower CTs could result in excessively large windows, and use of higher CTs could result in unrealistically small windows. Therefore, CTs less than c shall be treated the same as CT c , and CTs greater than d shall be treated the same as d , for purposes of calculating D , the correlation window.

(6) Default Correlation Windows. For the default values of Min CT = 7, Max CT = 10, minimum window size = 0.5 dm, and restricted CT = 4, the values of L and R in Table b result in the correlation windows shown in Table c.

Table c Correlation Windows (Value of D in dm) for Default Parameter Values

		Remote CT 13-15
Local CT	≥ 10	3.43 dm
	9	3.49 dm
	8	3.66 dm
	5-7	4.64 dm

(7) Velocity Test. The reported course of the remote track shall be within f degrees of the calculated course of the local track. The speed of the slower track shall be within g percent of the speed of the faster track, or within $g \cdot 20 / S_F$ percent for surface tracks, whichever is greater. Velocity comparisons shall use the last reported course and speed of remote tracks and the course and speed calculated for local tracks at the common time to which the tracks are extrapolated at the time of comparison.

g. Correlation Restrictions. Nodes shall not automatically correlate two tracks if local/remote data held indicates any of the following conditions exist. The restrictions do not apply to manual correlation except as noted in subparagraph 1.1d. No other correlation restrictions shall be applied for two tracks which pass the correlation tests specified in subparagraph 1.1f.

- (1) Both tracks are locally derived real-time tracks, i.e., being updated with local positional data.
- (2) One track is a common local track and the other is a remote, and the same unit has R^2 for both tracks.
- (3) Either track is currently the subject of a dual designation resolution action involving another TN.

h. Number of Correlation Tests. Two tracks shall pass the correlation tests and restrictions in subparagraphs f and g 2(1-2,1) times before the correlation is executed. When two tracks pass the correlation tests and restrictions once, they shall be deemed a tentative correlation. The same two tracks shall be tested again upon the next correlation stimulus (see subparagraph c). If the two tracks successfully pass the second correlation test and there is no correlation restriction, they shall be processed for dual designation resolution in accordance with subparagraphs j and k.

j. Dropped Track Number (TN-2) Selection. Nodes shall select the track with lower CT as the TN to be dropped, otherwise, shall select the higher TN as the TN to be dropped. The Owner PN of TN-1 will have R^2 on the track.

k. Execution of the Correlation. The following rules apply to the disposition of TN-2 and the retention of data from TN-2 upon origination

(1) Disposition of TN-2.

(a) If own node holds TN-2 as a local or common local track, the retained TN (TN-1) shall be designated as a common local track.

(2) TN-2 Data Retention. Data specified below shall be transferred from TN-2 to TN-1 when the correlation is executed. No other TN-2 data shall be transferred to TN-1. It is expected that normal reporting protocols will result in the establishment of the appropriate data for TN-1.

(a) Kinematic Data. If TN-2 is a local or common local track, TN-2's position, velocity, and CT shall be transferred to TN-1.

(b) IMO and MMSI data. If TN-2 is a local or common local track and TN-1 has no data, TN-2 IMO and MMSI numbers shall be transferred to TN-1.

(c) All other TN-1 fields with no data. If TN-2 is a local or common local track, TN-2 data shall be transferred to TN-1.

1.2 Resolution of Track Dual Designations

a. Correlation notification. When a Node recognizes that two tracks which are being reported to the BMM Network are eligible for correlation, that Node shall initiate action by any means (chat, voice, email, etc.).

1.3 Track Decorrelation. The following subparagraphs apply to the decorrelation of any two tracks.

a. Decorrelation Requirements. All Nodes that initiate tracks shall have an automatic decorrelation capability. Nodes may also perform manual decorrelation, and may have a capability to require manual confirmation of automatic decorrelations. Implementation of automatic and manual functions shall adhere to the following requirements:

(1) Automatic decorrelation tests shall be performed for each common local track upon receipt of each track.

(2) Common local tracks shall be decorrelated if, on receipt of 2(1-5, 1) consecutive remote track reports, the remote track falls outside a distance of 1.5(1.0-2.0, 0.1) times the maximum correlation distance calculated in accordance with subparagraph 1.1f(3).

b. Execution of the Decorrelation. After it has been determined that a common local track (TN A) satisfies the criteria of an automatic or manual decorrelation, the decorrelation shall be executed as follows:

	This document belongs to BlueMASSMED project's Partners. Any copy or use is forbidden without a prior written authorisation.	

(1) The local track shall be automatically tested once for correlation against remote tracks (not common local tracks) in accordance with subparagraphs 1.1f and g. If the automatic correlation test fails, assign a new TN (TN B) to the local track and report TN B.

(2) Establish TN A as a remote track.

2 REPORTING RESPONSIBILITY RULES AND CONFIDENCE_TYPE

The reporting of tracks reports is based upon reporting responsibility (R^2) rules as defined below. These rules are designed to limit reporting to a single node having the best available positional data on the track. Confidence_Type (CT) is used to determine which system has the best data. CT is a numerical value from 0 through 15 that is included in each Confidence_Type report. Value 0 indicates a nonreal-time report; values 1 through 15 indicate different degrees of reliability of the positional data. At time of transmission of a track report, the local CT is compared to the last received remote CT and a determination made to transmit or not to transmit the track report using the following rules:

a. The first unit to establish a track reports on that track.

b. A unit reporting a track is presumed to have R^2 for that track. A unit with R^2 for a real-time track shall relinquish R^2 upon receiving a remote real-time track report that meets the correlation criteria established on 1.1j.

c. A unit assumes R^2 on a common track if its local CT at time of transmission exceeds the remote CT by 3 when the remote CT value is 1 through 12. When the remote TQ is 13 or 14, a unit may assume R^2 when its local CT is 15.

d. A unit assumes R^2 if it has real-time data and nonreal-time data was received. Nonreal-time data is identified by a CT=0.

e. A unit assumes R^2 if it has not received a remote report on a local track for approximately 5 minutes, or has decremented remote CT such that subparagraph 2.c applies, whichever occurs first. For determining R^2 , if a remote report is not received, systems may decrement remote CT by one approximately every 30 seconds until the remote CT=1. CT=0 shall not be assigned by decrementing.

g. A unit without R^2 for a nonreal-time track (CT=0) shall assume R^2 for the track when the track is locally updated by a new nonreal-time report. A unit reporting a nonreal-time track is presumed to have R^2 regardless of the time value in the track report.

	This document belongs to BlueMASSMED project's Partners. Any copy or use is forbidden without a prior written authorisation.	
--	--	--

h. A unit with responsibility for reporting a track retains the responsibility until relinquished in accordance with the above rules or until track is dropped.

i. A track shall not be part of the SBCMP if the track has not been updated in 6 minutes for real time tracks and 30 minutes for nonreal-time tracks.

3. TRACK NUMBER DEFINITION

Track Numbering will have the following criteria:

Data structure: aannnnn

Coding for aa:

00 → IT

01 → FR

02 → SPA

03 → SPG

04 → PT

Coding for nnnnn:

Decimal numbers from 00001 to 99999

When a node reaches 99999, it shall start again from 00001. Each system is responsible to avoid TN duplication.

4. CONFIDENCE TYPE DEFINITION

The Confidence Type is stated as a numerical value from 1 to 15 with the higher values indicating the higher Confidence Type. The CT is based on the positional accuracy of a track represented by an area in square data miles within which it is assessed that there is a 95% probability that the track lies.

Coding:

0 - Non real-time track

track report is identified as a nonreal-time report with CT = 0 if the track data have been derived from other than integrated sensors.

- 1 - > 2,755 SQUARE DATA MILES
- 2 - EQUAL TO OR < 2,755 SQUARE DATA MILES
- 3 - EQUAL TO OR < 686 SQUARE DATA MILES
- 4 - EQUAL TO OR < 439 SQUARE DATA MILES
- 5 - EQUAL TO OR < 247 SQUARE DATA MILES
- 6 - EQUAL TO OR < 110 SQUARE DATA MILES
- 7 - EQUAL TO OR < 27.0 SQUARE DATA MILES
- 8 - EQUAL TO OR < 4.4 SQUARE DATA MILES
- 9 - EQUAL TO OR < 1.10 SQUARE DATA MILES
- 10 - EQUAL TO OR < 0.0281 SQUARE DATA MILES
- 11 - EQUAL TO OR < 0.0070 SQUARE DATA MILES
- 12 - EQUAL TO OR < 0.0018 SQUARE DATA MILES
- 13 - EQUAL TO OR < 0.0004 SQUARE DATA MILES
- 14 - EQUAL TO OR < 0.0001 SQUARE DATA MILES
- 15 - EQUAL TO OR < 0.00003 SQUARE DATA MILES

ANNEX III
WSDL rev. 1.2.1